



Andela GP-MegaMini

Glass Pulverizer/Screeners with Infeed Conveyor

**Accepts all
types of glass**

**Produce both glass sand
and glass aggregates,
separated
from larger debris**

Infeed Conveyor

**Total System: 7 HP
3 phase 240-480V**

Environmentally friendly

Reduces waste

*Provides cost effective remedy
for environmentally conscious
communities*

ANDELA PRODUCTS

493 State Route 28
Richfield Springs, NY 13439
315-858-0055

www.andelaproducts.com
info@andelaproducts.com



- Process 1500-2000 pounds of glass per/hour.
- Infeed all types of glass, no pre-cleaning required.
- Produce both a glass sand and glass aggregate, without sharp edges.
- Integrated trommel screen separates out the residue (caps, labels, and corks).
- Compact and integrated unit with Pulverizer, Trommel Screen, and Elec Controls

- Quiet operation
- Simple to operate and maintain
- Reasonably priced
- Industrial strength design
- Cleated rubber conveyor with self cleaning tail pulley
- Big machine features with a small machine



ANDELA GLASS PULVERIZER SYSTEM

MODEL GP-MegaMini

**Bulk Fed GP-MM Pulverizer with Trommel Screen and Conveyor
1500-2000 lbs. / hour**

MACHINE SPECIFICATIONS

Dimensions

Overall Length 162”
Overall Width 99”
Overall Height 140”
Approx. Shipping Weight Machine- 3250 lbs. / Conveyor- 1700 lbs.

Pulverizer

Machine Input Opening 12” x 12”
Barrel Diameter and Length 16” x 34”
Barrel Liner CC Abrasion Resistant Steel
Motor Size 5 hp
Solid Steel Shaft Diameter 2”
Number of Hammers 28
Hammer Type Flailing Arm/Hardened Steel
Bearing Size 2” Heavy Duty
Seal Protection 2 Seals at Each Shaft Bearing

Trommel

Screen Barrel Diameter and Length 21” OD x 4’-7” long
..... 21 in. x 24 in. sand screen and 21 in. x 21 in. aggregate screen
Rotating Brush 7” diameter
Screen Type Stainless Steel Woven Wire
Motor Size 1 hp

Conveyor

Belt Type 14 Troughing, 3 in. Cleated Rubber Belt, Self-Cleaning Tail Pulley
Motor 1 hp

Safety Features

E-Stop
Protective Guards Cover Input Hopper, Drive Unit and Bearings

Electrical – Control Panel Included Pre-wired to Motors

Motor Voltage 230/460V, 60 Hz 3 Phase (Or to Customer Specifications)
Controls Push Button Start/Stop

The manufacturer reserves the right to change designs
and specifications without notice.

Heavy Duty Design Highlights

High quality, low maintenance design for abrasion resistance

Heavy duty construction to outlast competitors

Chromium Carbide Liners last up to 6,000 hours

Produces crushed and/or pulverized glass with no sharp edges.

Two sizes: Glass Sand and Glass Aggregate

Use locally to replace sand or gravel in landscaping, construction, or other applications.

Electrical Control Panel

Enclosures - Enclosures are rated per the environment and are NEMA 4 or better. All enclosures are supplied with an emergency stop.

Main Disconnect - The main disconnect is provided with fuses or a circuit breaker and has a “Lockout/Tag out” feature.

Motor Starters - The motor starters are IEC rated.

Branch Circuit Protectors - The Branch circuit protectors are provided with a circuit breaker and a motor overload as an integral part of the unit.

Push Buttons - All push buttons are heavy duty dust tight/water tight design.

Standards - Built to UL-508 Industrial Standards. Electrical schematics and parts lists are supplied with the unit when the whole system is shipped. Can be CE certified upon request.

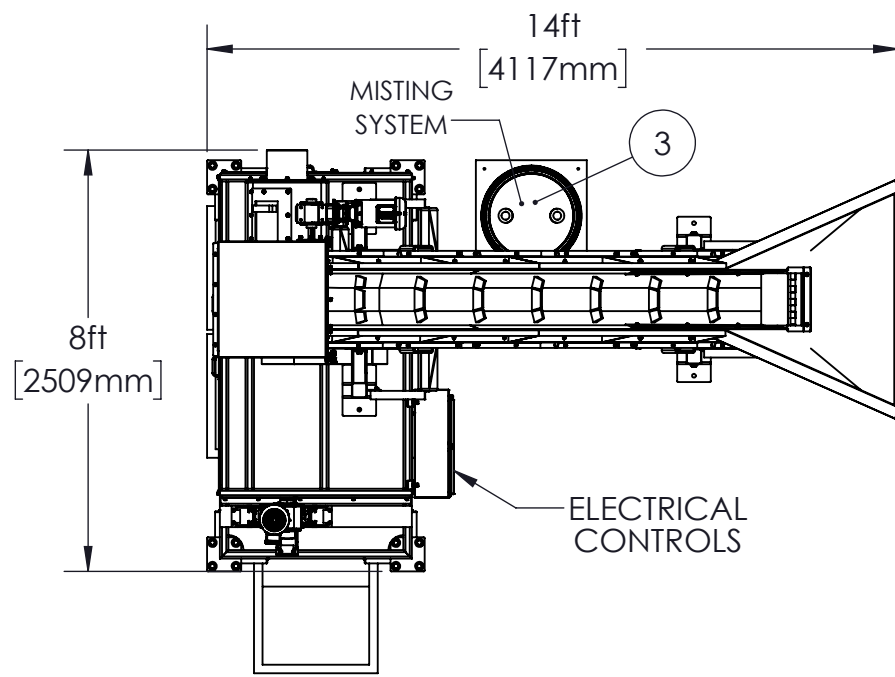

TIP BINS ARE FOR REFERENCE ONLY AND WILL BE PROVIDED BY CUSTOMER

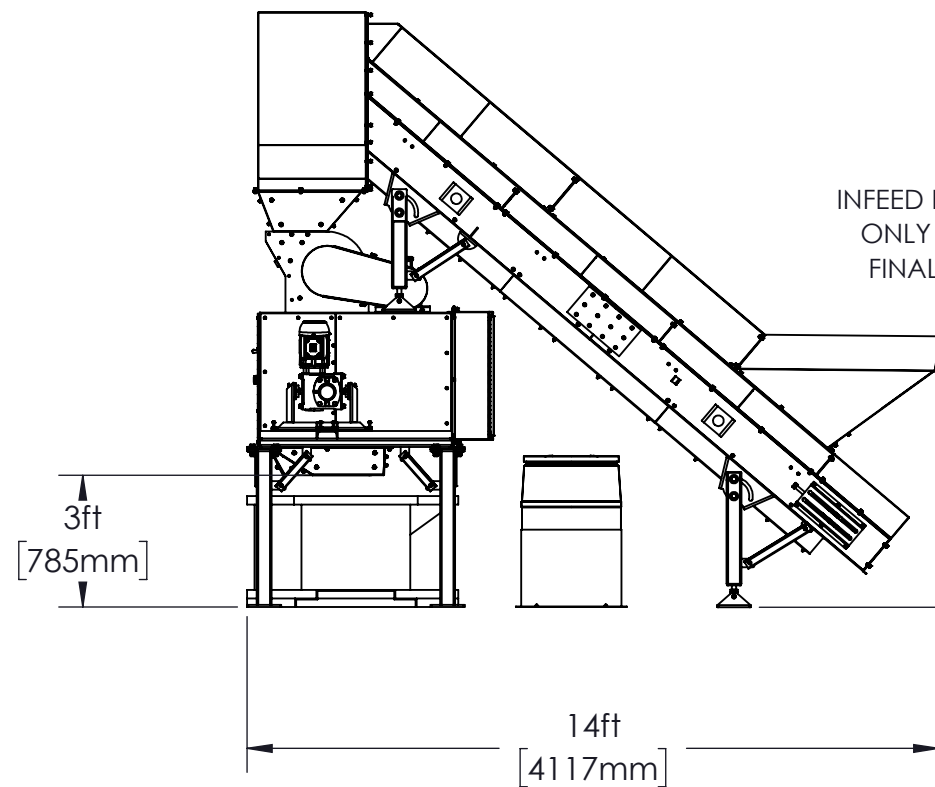
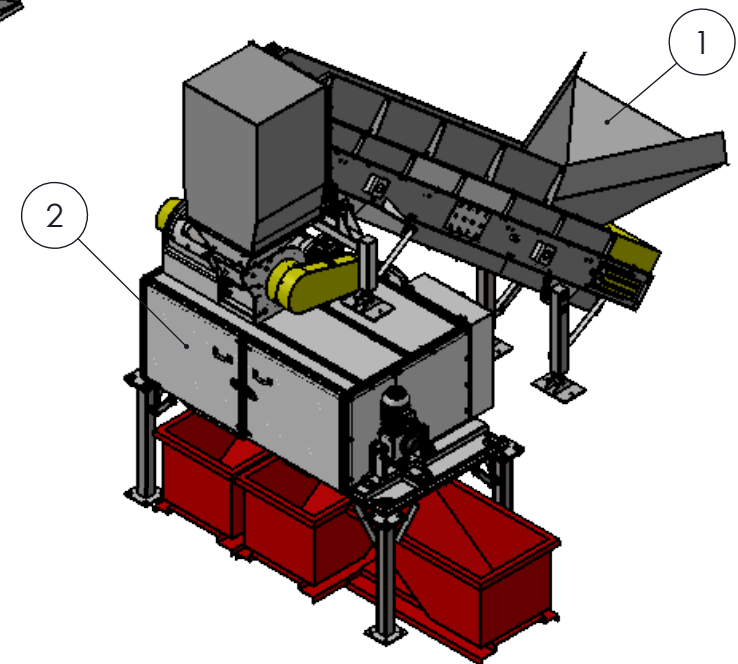
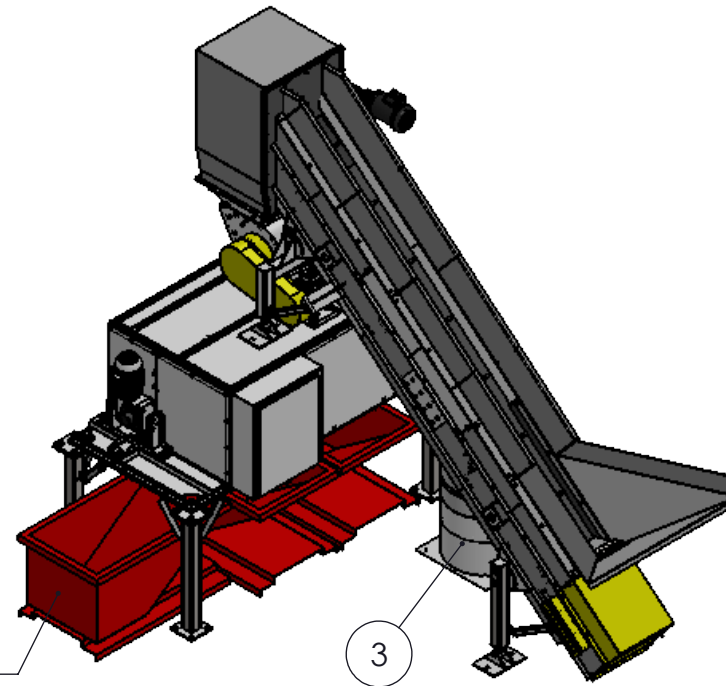

INFEED HEIGHT IS FOR REFERENCE ONLY AND MAY DIFFER AFTER FINAL ASSEMBLY AND SET UP

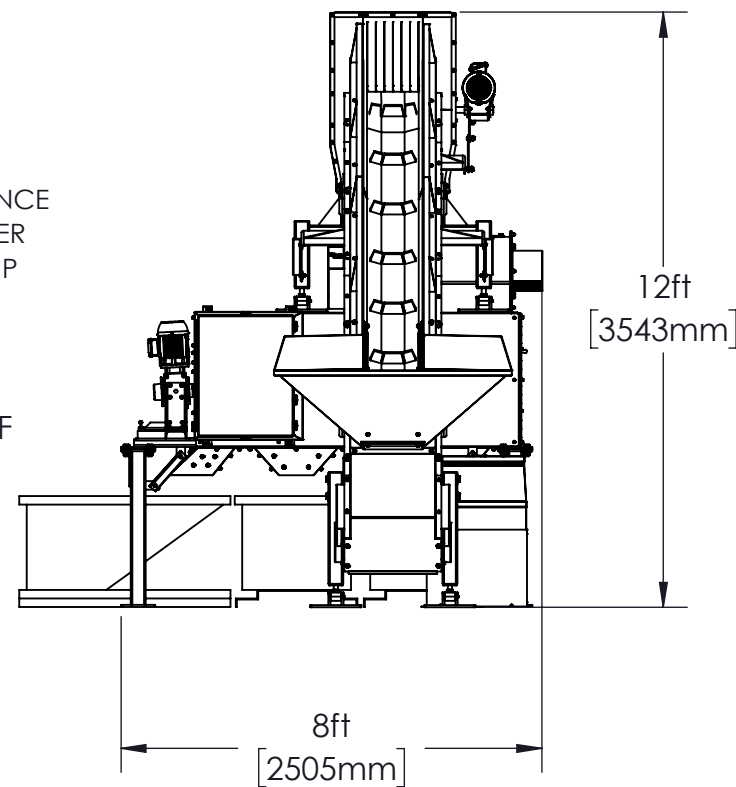

THIS DRAWING IS INTENDED FOR PROPOSAL PURPOSES ONLY AND ALL DIMENSIONS ARE FOR REFERENCE ONLY AND MAY VARY PER CUSTOMER ACTUAL DESIGNS, DIMENSIONS AND DETAILS MAY VARY AFTER DETAILING AND FINALIZATION

ITEM	DESCRIPTION	H.P.
1	14"x14' Troughing Conveyor w/High Sides	1 Hp
2	GPMM Pulverizer/Trommel	5 Hp / 1 Hp
3	Misting System	1/12 Hp



493 State Route 28
Richfield Springs, NY 13439
Tel: 315-858-0055
andelaproducts.com

DRAWN BY:
RJY
MODELED BY:
RJY
DATE:
2/11/2025
CHECKED BY:
SCALE:
1:40

GP-MM
GLASS PULVERIZER-MEGA MINI SYSTEM

ANDELA PRODUCTS

ALL EQUIPMENT PAINTED RAL-5015 SKY BLUE, ALL GUARDS AND RAILINGS PAINTED RAL-1023 TRAFFIC YELLOW, AND ALL PLATFORMS PAINTED RAL-9017 TRAFFIC BLACK, UNLESS OTHERWISE NOTED.

GP-MM

SHEET 1 OF 1

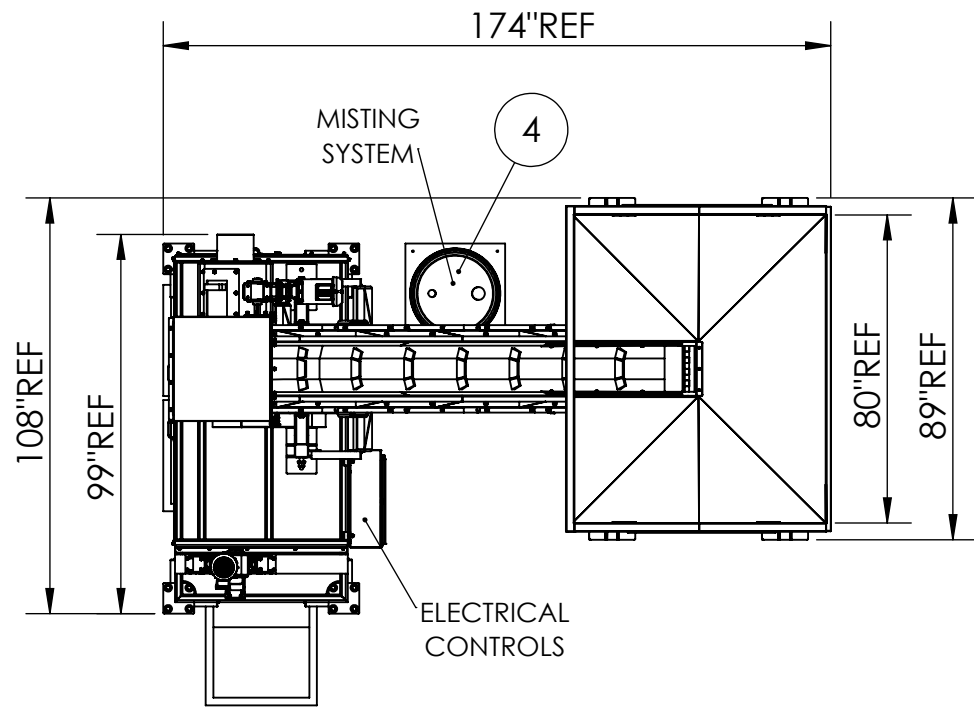

TIP BINS ARE FOR REFERENCE ONLY AND WILL BE PROVIDED BY CUSTOMER

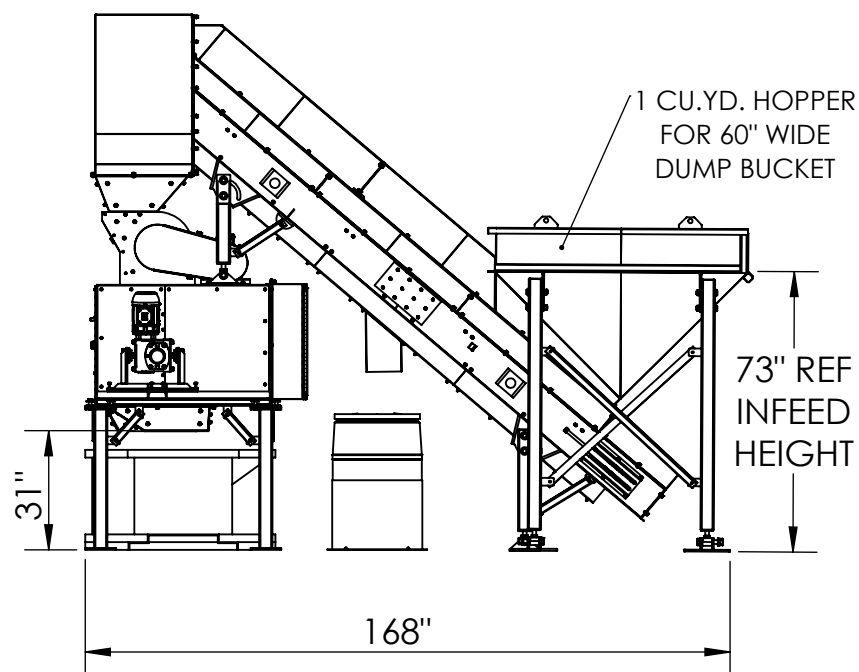
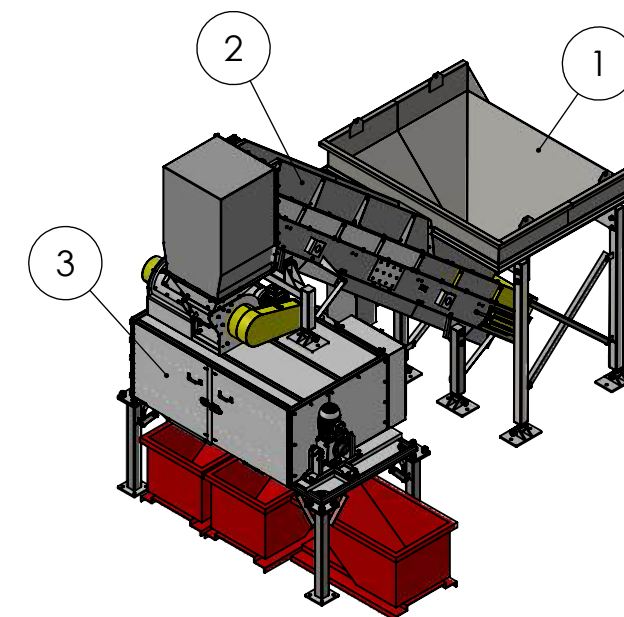
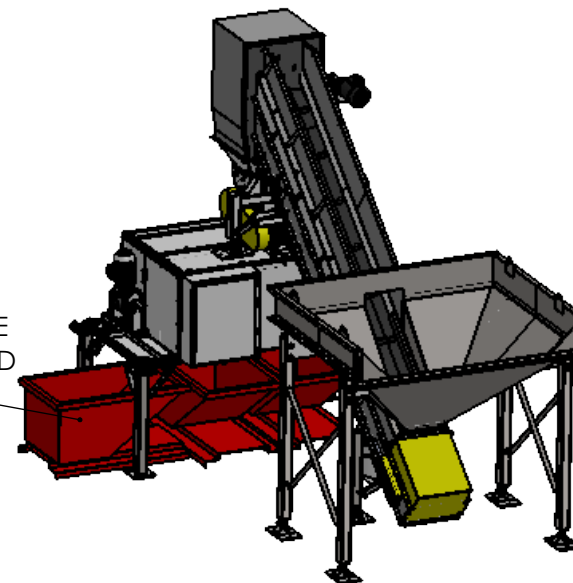

INFEED HEIGHT IS FOR REFERENCE ONLY AND MAY DIFFER AFTER FINAL ASSEMBLY AND SET UP

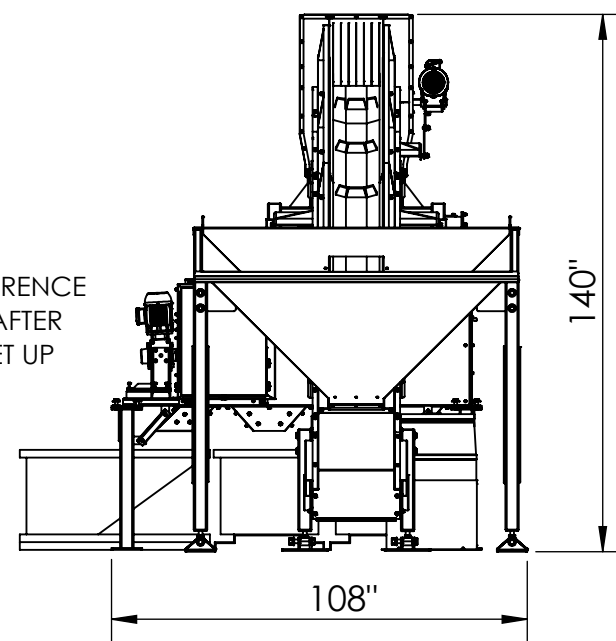

THIS DRAWING IS INTENDED FOR PROPOSAL PURPOSES ONLY AND ALL DIMENSIONS ARE FOR REFERENCE ONLY AND MAY VARY PER CUSTOMER. ACTUAL DESIGNS, DIMENSIONS AND DETAILS MAY VARY AFTER DETAILING AND FINALIZATION

NOTES:

- 1) SPECIFY ELECTRICAL REQUIREMENTS FOR SYSTEM:
PHASE : Single Phase

FREQUENCY : 60 HZ.

VOLTAGE : 220 V
- 2) ALL DIMENSIONS ARE REFERENCE DIMENSIONS AND MAY VARY PER CUSTOMERS SPECIFICATIONS
- 3) MISTING SYSTEM LOCATION TO BE DETERMINED BY CUSTOMER.

APPROVAL

BY: (PRINT) _____
 BY: (SIGN) _____
 DATE: _____
 AS NOTED: _____

ITEM	DESCRIPTION	H.P.
1	1 Cu. Yrd. Dump Hopper	N/A
2	14"x 14' Troughing Conveyor w/High Sides	1 HP
3	GPMM Pulverizer/Trommel	5 HP/1 HP
4	Misting System	1/12 HP



493 State Route 28
Richfield Springs, NY 13439

Tel: 315-858-0055
andelaproducts.com

DRAWN BY:
RJY
 MODELED BY:
RJY
 DATE:
7/11/2024
 CHECKED BY:
 SCALE:
1:64

GP-MM
GLASS PULVERIZER-MEGA MINI SYSTEM
w 1 CU. YD. DUMP HOPPER

ANDELA PRODUCTS

ALL EQUIPMENT PAINTED RAL-5015 SKY BLUE,
ALL GUARDS AND RAILINGS PAINTED RAL-1023 TRAFFIC YELLOW, AND ALL PLATFORMS PAINTED RAL-9017 TRAFFIC BLACK, UNLESS OTHERWISE NOTED.

GP-MM

SHEET 1 OF 1

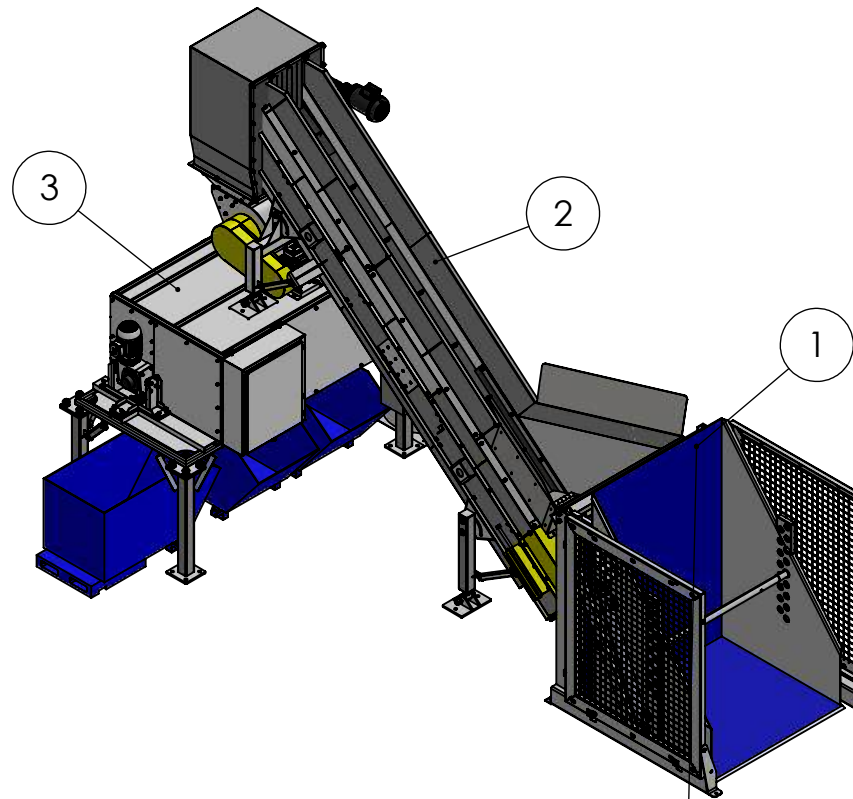
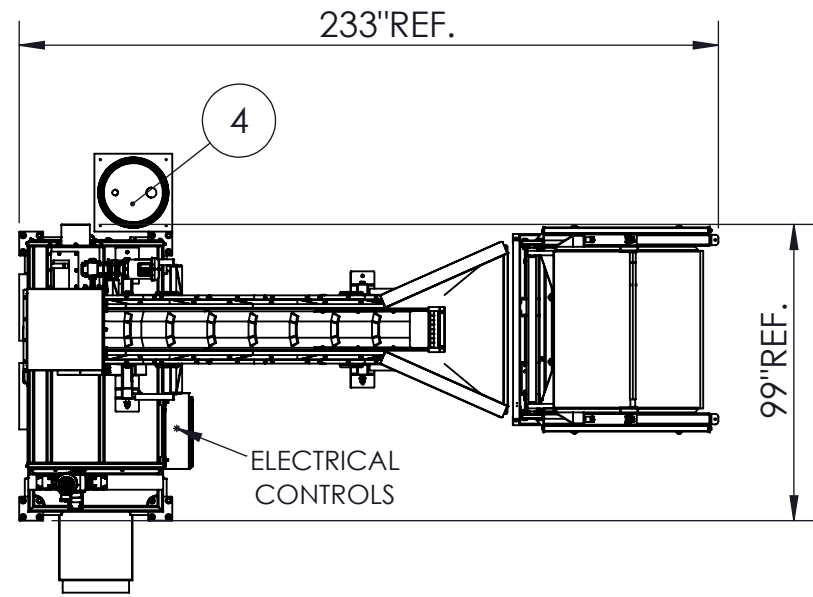

NOTES:
 1) SPECIFY ELECTRICAL REQUIREMENTS FOR SYSTEM:
 PHASE : 3 Phase
 FREQUENCY : _____
 VOLTAGE : _____
 2) ALL DIMENSIONS ARE REFERENCE DIMENSIONS AND MAY VARY PER CUSTOMERS SPECIFICATIONS
 3) MISTING SYSTEM LOCATION TO BE DETERMINED BY CUSTOMER.

APPROVAL

BY: (PRINT) _____
 BY: (SIGN) _____
 DATE: _____
 AS NOTED: _____

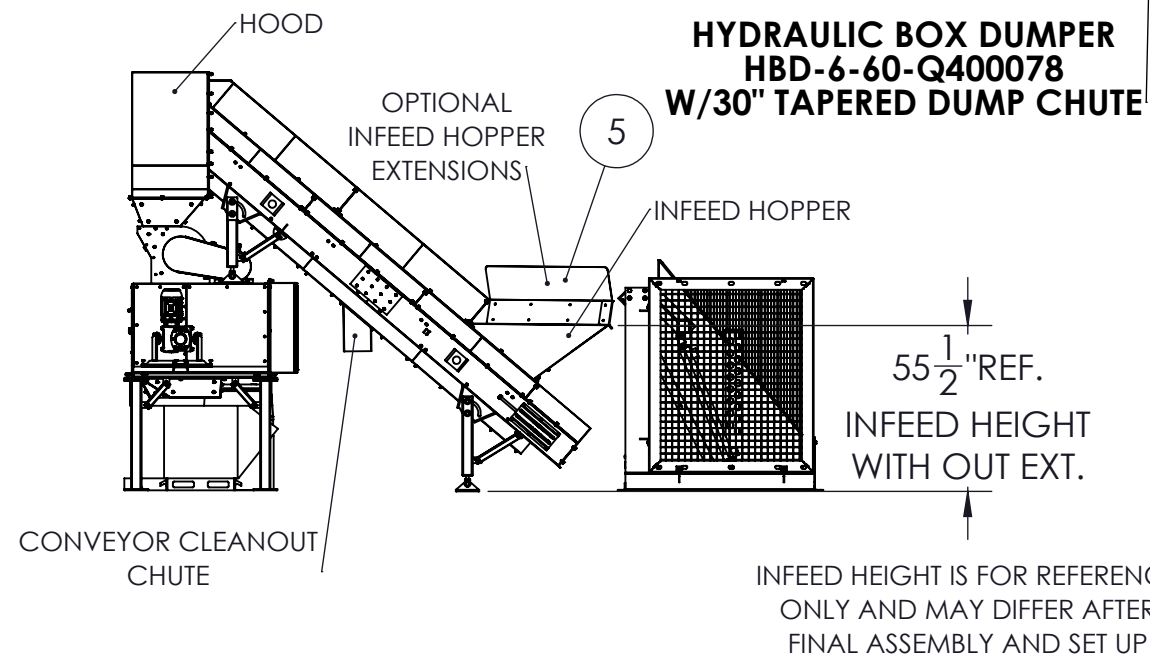
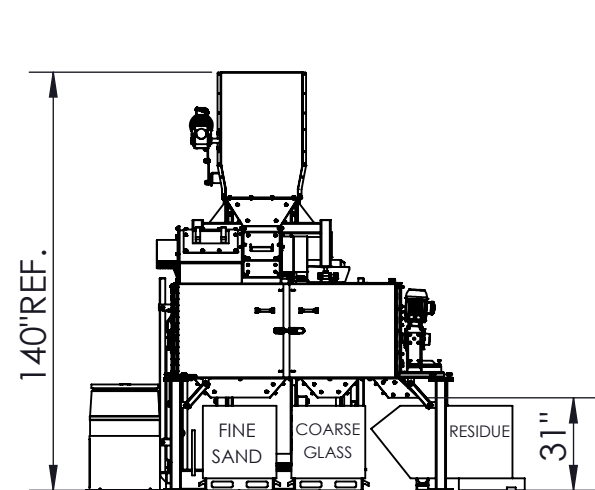

**HYDRAULIC BOX DUMPER
 HBD-6-60-Q400078
 W/30" TAPERED DUMP CHUTE**

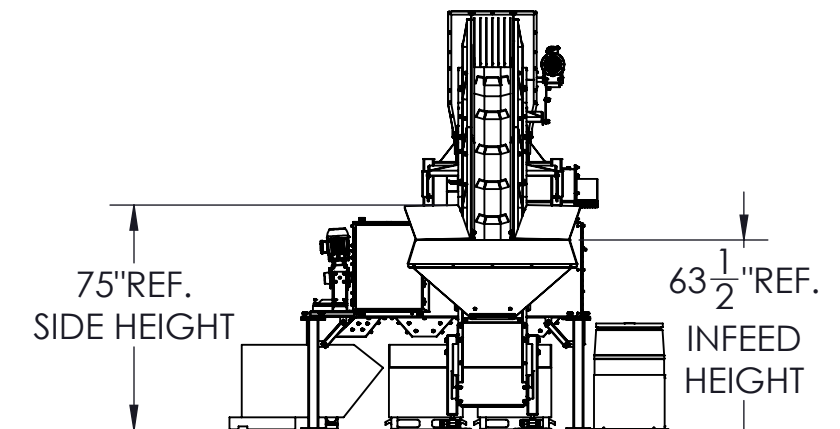

OPTIONAL HOPPER EXTENSIONS
 ADD APPROX. 11" TO HOPPER SIDE HEIGHT
 AND 8" TO INFEED HEIGHT

THIS DRAWING IS INTENDED FOR PROPOSAL PURPOSES ONLY AND ALL DIMENSIONS ARE FOR REFERENCE ONLY AND MAY VARY PER CUSTOMER. ACTUAL DESIGNS, DIMENSIONS AND DETAILS MAY VARY AFTER DETAILING AND FINALIZATION

INFEED HEIGHT IS FOR REFERENCE ONLY AND MAY DIFFER AFTER FINAL ASSEMBLY AND SET UP

ITEM #	DESCRIPTION	H.P.
1	Vestil Box Tipper (HBD-6-60)	5.5 Hp
2	14" x 14' Troughing Conveyor w/High Sides	1 Hp
3	GPMM Pulverizer/Trommel	5 Hp / 1 Hp
4	Misting System	1/12 Hp
5	Optional Infeed Hopper Extensions	N/A



493 State Route 28
 Richfield Springs, NY 13439
 Tel: 315-858-0055
 andelaproducts.com

DRAWN BY: RJY
 MODELED BY: RJY
 DATE: 7/11/2024
 CHECKED BY:
 SCALE: 1:64

GP-MM
 GLASS PULVERIZER-MEGA MINI SYSTEM
 w/ BOX TIPPER

ANDELA PRODUCTS

ALL EQUIPMENT PAINTED RAL-5015 SKY BLUE, ALL GUARDS AND RAILINGS PAINTED RAL-1023 TRAFFIC YELLOW, AND ALL PLATFORMS PAINTED RAL-9017 TRAFFIC BLACK, UNLESS OTHERWISE NOTED.

GP-MM
 SHEET 1 OF 1

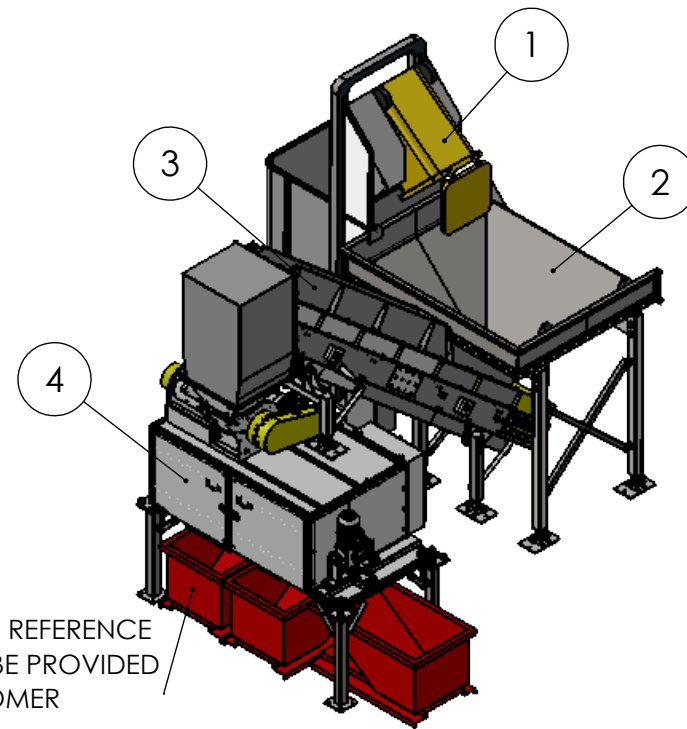
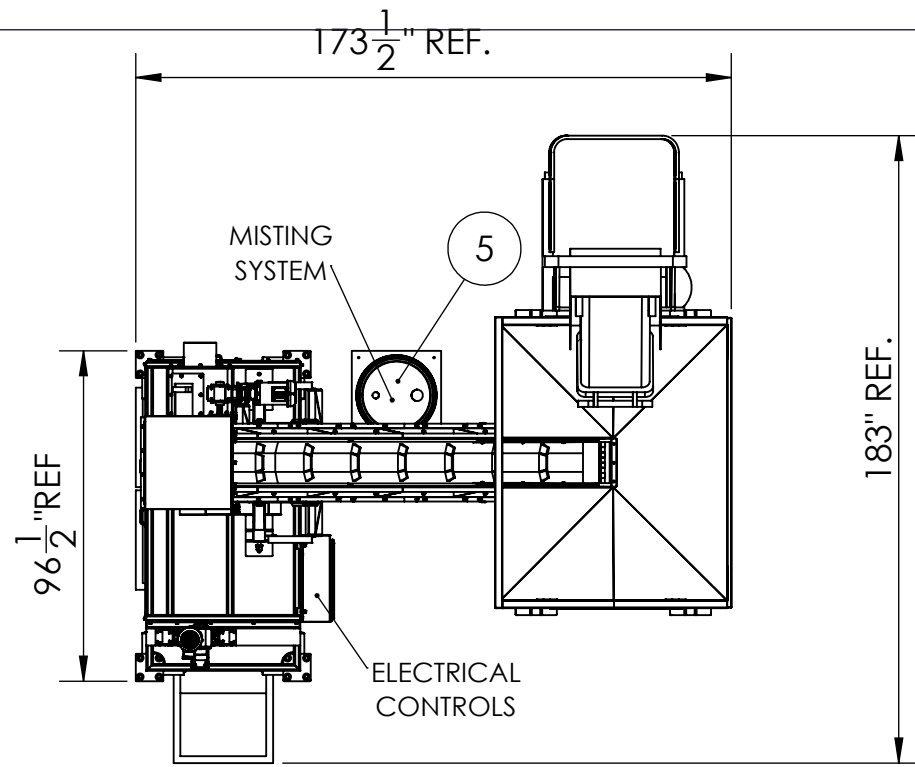

TIP BINS ARE FOR REFERENCE ONLY AND WILL BE PROVIDED BY CUSTOMER

NOTES:

- 1) SPECIFY ELECTRICAL REQUIREMENTS FOR SYSTEM:
 PHASE : 3 Phase
 FREQUENCY : _____
 VOLTAGE : _____
- 2) ALL DIMENSIONS ARE REFERENCE DIMENSIONS AND MAY VARY PER CUSTOMERS SPECIFICATIONS
- 3) MISTING SYSTEM LOCATION TO BE DETERMINED BY CUSTOMER.

APPROVAL

BY: (PRINT) _____
 BY: (SIGN) _____
 DATE: _____
 AS NOTED: _____

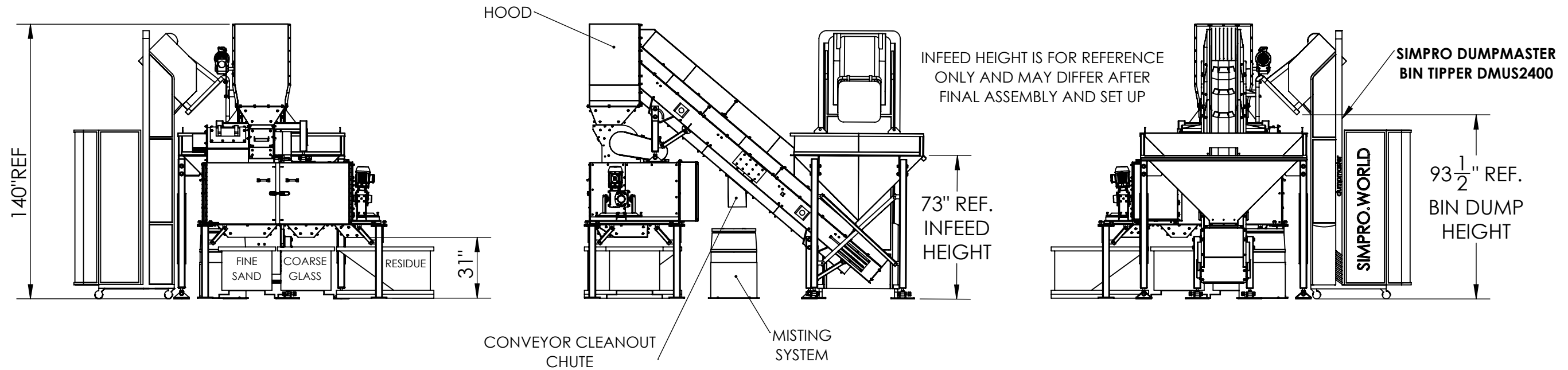

THIS DRAWING IS INTENDED FOR PROPOSAL PURPOSES ONLY AND ALL DIMENSIONS ARE FOR REFERENCE ONLY AND MAY VARY PER CUSTOMER. ACTUAL DESIGN, DIMENSIONS AND DETAILS MAY VARY AFTER DETAILING AND FINALIZATION

ITEM #	DESCRIPTION	H.P.
1	Simpro Dumpmaster Bin Tipper DMUS2400	1 Hp
2	1 Cu. Yrd. Dump Hopper	N/A
3	14'x14' Troughing Conveyor w/High Sides	1 Hp
4	GPMM Pulverizer/Trommel	5 Hp / 1 Hp
5	Misting System	1/12 Hp



493 State Route 28
 Richfield Springs, NY 13439
 Tel: 315-858-0055
 andelaproducts.com

DRAWN BY: RJJ
 MODELED BY: RJJ
 DATE: 7/11/2024
 CHECKED BY:
 SCALE: 1:64

GP-MM
 GLASS PULVERIZER-MEGA MINI SYSTEM
 w/CANE TIPPER

ANDELA PRODUCTS

ALL EQUIPMENT PAINTED RAL-5015 SKY BLUE, ALL GUARDS AND RAILINGS PAINTED RAL-1023 TRAFFIC YELLOW, AND ALL PLATFORMS PAINTED RAL-9017 TRAFFIC BLACK, UNLESS OTHERWISE NOTED.

GP-MM

SHEET 1 OF 1