



# Andela

# GR-8

## Glass Bottle Crusher

**Quiet and simple**

**Accepts 8" dia. bottles**

**1/2 HP**

**220V single phase**

**Volume reduction reduces  
cost of handling/shipping**

**Durable construction to  
handle abrasive glass**

*Environmentally friendly*

*Reduces waste*

*Provides cost effective remedy  
for environmentally conscious  
communities*

### **ANDELA PRODUCTS**

493 State Route 28  
Richfield Springs, NY 13439

**(315) 858-0055**

**[www.andelaproducts.com](http://www.andelaproducts.com)  
[info@andelaproducts.com](mailto:info@andelaproducts.com)**



- Industrial bottle crusher; up to 60 bottles/min & up to 8 inches in diameter.
- Heavy duty chromium carbide wear parts and sealed bearings for durability.
- Patented flexible hammers prevent clogging.
- No need to remove caps/corks.
- Compact design.
- Up to 80% volume reduction.

- Quiet Operation
- Simple to use and maintain
- Reasonably priced
- Industrial duty design and construction
- Reduces wine and liquor bottles with ease
- Shipped complete and ready for operation

**ANDELA BOTTLE CRUSHER MODEL GR-8**

**MACHINE SPECIFICATIONS**

**Dimensions**

Overall Length ..... 39”  
Overall Width ..... 25”  
Overall Height ..... 52”  
Hopper Input Opening ..... 7” Diameter  
Frame Construction ..... Welded Steel with Abrasion Resistant Steel Liners

**Drive Componentry**

Motor Size ..... (1) 1/2 HP  
Solid Steel Shaft Diameter ..... 1”  
Number of Hammers ..... 4  
Hammer Type ..... Heavy Duty Flexible Arm – Chromium Carbide Steel  
Bearing Size ..... 1”

**Safety Features**

Protective Guards ..... Cover on Input, Drive Unit, and Bearings

**Electrical**

Motor Voltage ..... 115/208-230V, Single Phase or to Customer Specifications

**Shipping**

Approximate Weight ..... 500 LBS

The manufacturer reserves the right to change designs  
and specifications without notice.

TOP VIEW

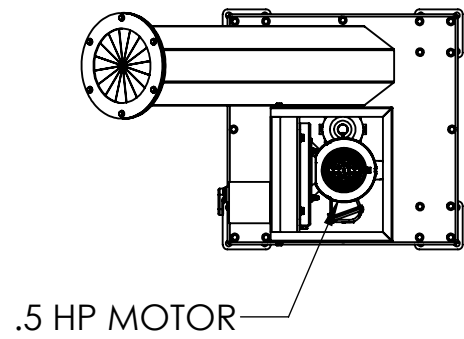

BOTTOM VIEW

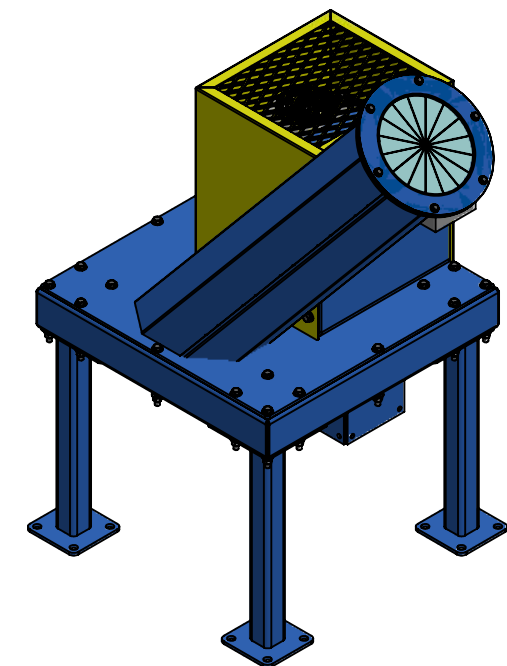
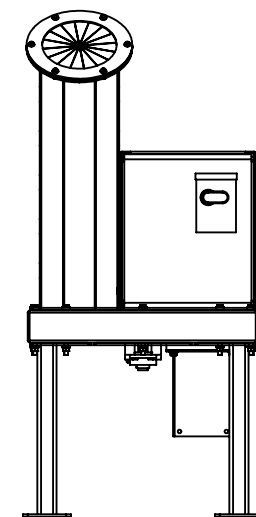
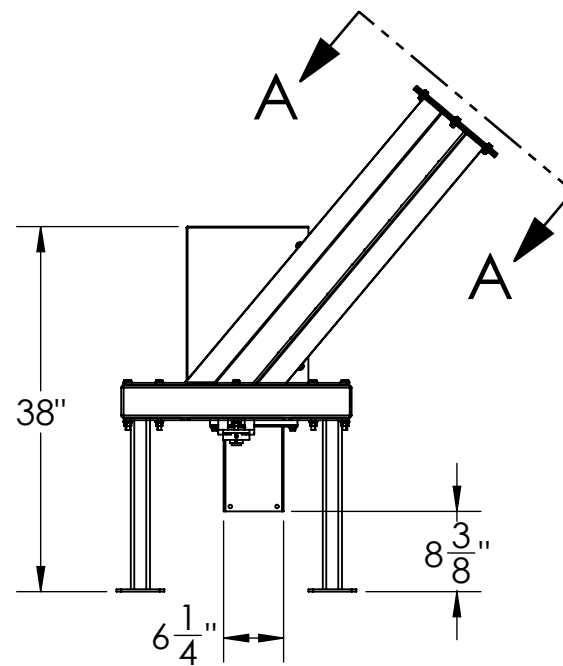
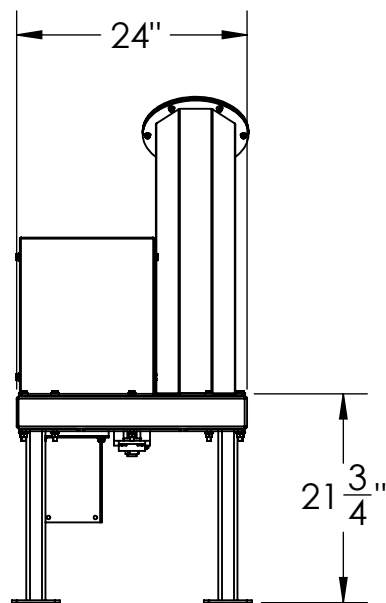
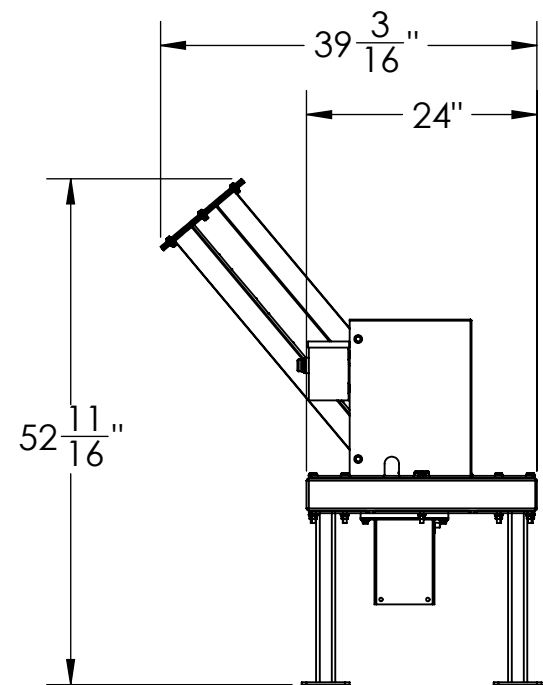
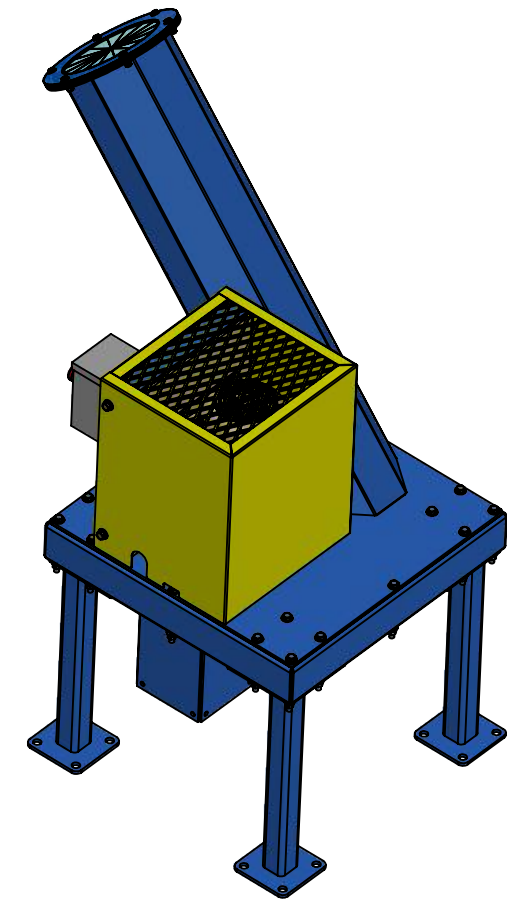
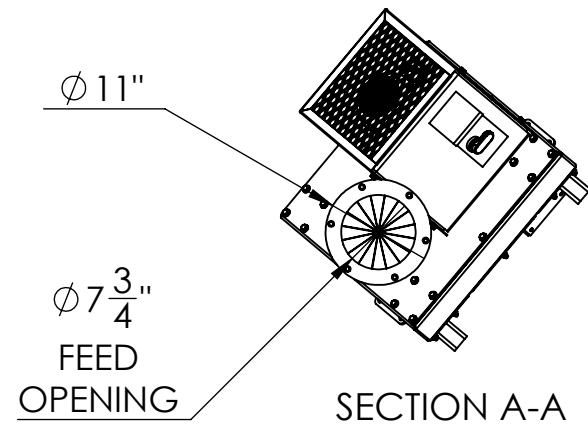
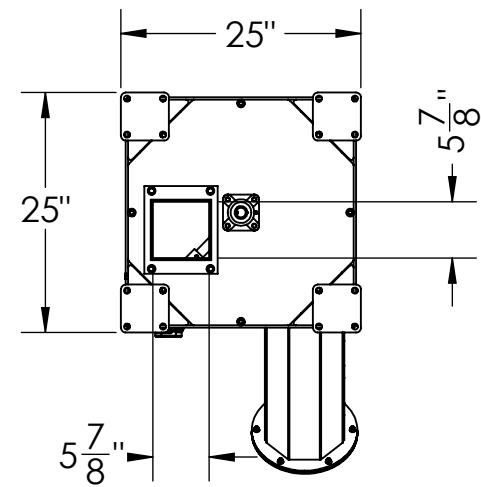

493 State Route 28  
Richfield Springs, NY 13439  
Tel: 315-858-0055  
andelaproducts.com

DRAWN BY:  
JEA  
MODELED BY:  
JEA  
DATE:  
7/12/2023  
CHECKED BY:  
SCALE:  
1:20

GR-8  
GR8 BOTTLE BREAKER

ANDELA PRODUCTS

REVISION	DATE	FILE NO

ALL EQUIPMENT PAINTED RAL-5015 SKY BLUE, ALL GUARDS AND RAILINGS PAINTED RAL-1023 TRAFFIC YELLOW, AND ALL PLATFORMS PAINTED RAL-9017 TRAFFIC BLACK, UNLESS OTHERWISE NOTED.

GR-8

SHEET 1 OF 1