

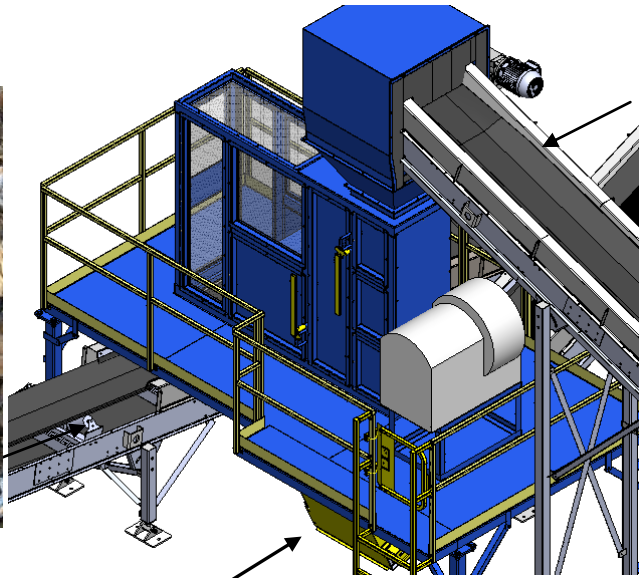

Andela

GLASS CLEAN-UP UNIT

Separated Residue



Single Stream Mixed Glass



Cleaned Glass Cullet



The Andela Glass Clean-Up Unit will separate glass cullet from paper shred and residue.

Simple low power solution. No vacuums or dust collection required. Access panels for maintenance.

Glass cullet and residue discharge into tip-bins, conveyors or bunkers. Integrate into your existing MRF system.

- Simple to operate and maintain
- Reasonably priced
- Durable
- Totally enclosed with access doors

ANDELA PRODUCTS

493 State Route 28
Richfield Springs, NY
13439
Phone: (315) 858-0055

www.andelaproducts.com
info@andelaproducts.com



www.andelaproducts.com

ANDELA GLASS CLEAN-UP UNIT
MODEL GCU-24

MACHINE SPECIFICATIONS

Dimensions

Overall Length 177”
Overall Width 108”
Overall Height 184”
Input Opening.....18” x 18”
Shipping Weight.....Approximately 6,300lbs

Features

Contact Surfaces are Covered With Wear Resistant Liners
Hand Adjustments to Easily Accommodate Wet & Dry Feedstock
Enclosure.....Sheet Metal
.....Hinged Service Door
Maintenance Easy Access Insert Panels

Drive Componentry

Motor Size..... 3 hp

Safety Features

Protective Guards Totally Enclosed System
..... Platform with self-closing ladder guard and railings

Electrical

Motor Voltage..... 230/460 VAC, 60 HZ, 3 phase
(or to customer specifications)
Controls.....Push Button Start/Stop with Integrated VFD

The manufacturer reserves the right to change designs
and specifications without notice.