



Andela

AGB-06HD

AGB-06 HD Glass Crusher

5 TPH

Efficient Size Reduction

Flexible Impact Hammers

Product Destruction

Glass Cullet Processing

Commingled Container Processing & Separation

Model:

AGB-06: 5 TPH

*Reduces waste
Provides a cost effective remedy
for environmentally conscious
communities*

ANDELA PRODUCTS

493 State Route 28
Richfield Springs, NY 13439

Phone: (315) 858-0055

www.andelaproducts.com
info@andelaproducts.com



- The Andela AGB-06HD Glass Crusher is used for glass cullet production or to efficiently reduce and separate mixed glass from a commingled mix of glass, plastic and aluminum.
- The flexible impact hammers will liberate and crush glass, ceramics and other breakable materials.
- Specifically designed, engineered, and outfitted with select abrasion resistant materials to endure the rigors of glass processing.
- Simple to operate and maintain
- Low power requirements for significant size reduction
- Will process a mix of glass and other materials selective size reduction
- Big machine features with a small machine price
- Heavy duty construction



ANDELA BREAKER MODEL AGB-06HD

The Andela Breaker is ideally suited to many applications because of its durability, flexibility, and design. This equipment is unique in its ability to successfully process a broad range of items using a technology that selectively reduces certain material while leaving others whole.

MACHINE SPECIFICATIONS

Dimensions

Overall Length	62"
Overall Width	77"
Overall Height	Variable
Input Opening	36" x 24"
Frame Construction	Welded Steel with 1/4" to 3/4" Thick Abrasion Resistant Replaceable Bolt In Steel Liner Plates Heavy Duty Frame with Vibration Isolation (4) Mechanical Spring Isolators

Drive Componentry

Motor Size	(1) 7.5 hp
Solid Steel Shaft Diameter	2-1/2"
Number of Hammers	12
Hammer Type	Heavy Duty Flailing Arm of Through Hardened Steel
Bearing Size.....	2-1/2"

Safety and Maintenance Features

Protective Guards	Cover Input Drive Unit and Bearings
Access Door.....	Removable Panels for Hammer and Liner Maintenance

Electrical

Motor Voltage	230/460VAC, 60 HZ, 3 Phase (or to customer specifications)
---------------------	---

The manufacturer reserves the right to change designs and specifications without notice.

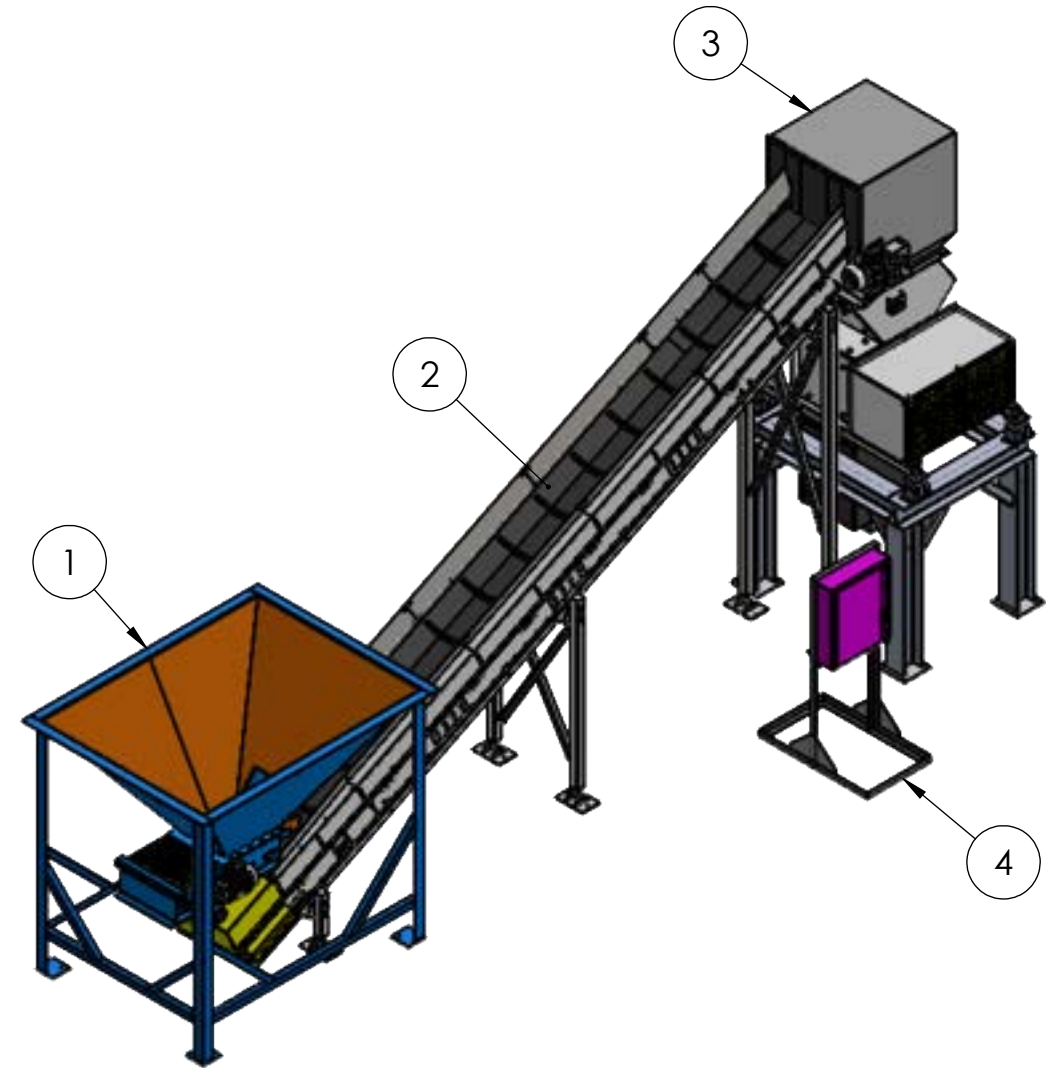
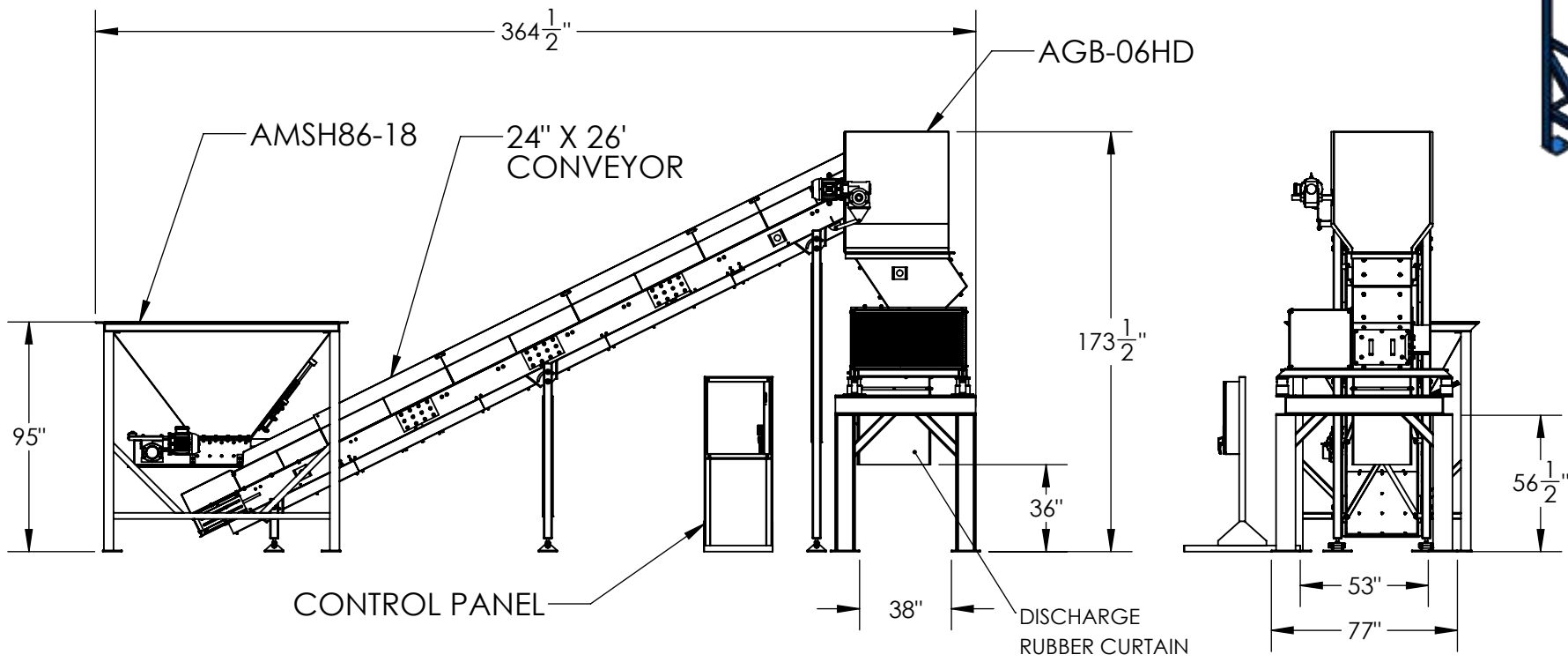
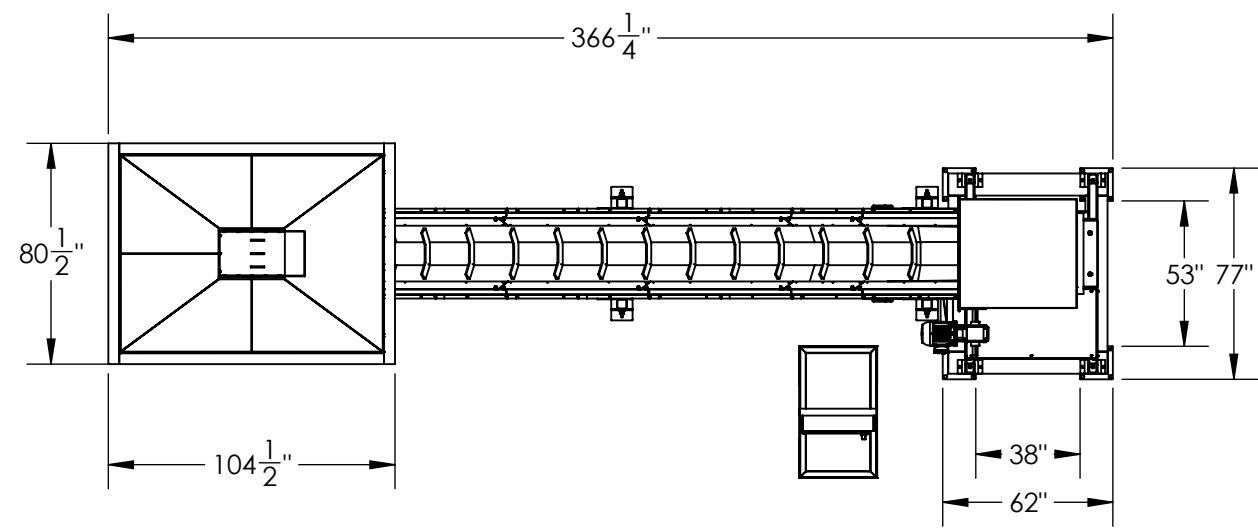

ANDELA GLASS CRUSHER SYSTEM - AGB-06HD				
ITEM NO.	PART-ITEM NO.	DESCRIPTION	HORSE POWER	QTY.
1	AMSH86-18	AMSH86-18 SURGE HOPPER	3 H.P.	1
2	24IN X 26FT CONV	24" X 26' CONVEYOR	3 H.P.	1
3	AGB-06HD	GLASS BREAKER on STAND	7.5 H.P.	1
4	CP-HD	CONTROL PANEL AND STAND	N/A	1



493 State Route 28
Richfield Springs, NY 13439
Tel: 315-858-0055
andelaproducts.com

DRAWN BY:
MB
MODELED BY:
MB
DATE
3/6/2024
CHECKED BY:
SCALE
1:70

ANDELA GLASS CRUSHER SYSTEM
AGB-06HD

ANDELA PRODUCTS

REVISION	DATE	FILE NO

ALL EQUIPMENT PAINTED RAL-5015 SKY BLUE, ALL GUARDS AND RAILINGS PAINTED RAL-1023 TRAFFIC YELLOW, AND ALL PLATFORMS PAINTED RAL-9017 TRAFFIC BLACK, UNLESS OTHERWISE NOTED.

ANDELA GLASS CRUSHER SYSTEM
SHEET 1 OF 1



Andela

Hoppers

Surge Hopper

**Evenly Distributes
Material**

**Essential for Bulk
Loading**

Models:

AMSH86-18

AMSH86-24

Environmentally friendly

Reduces waste

*Provides cost effective remedy
for environmentally conscious
communities*

ANDELA PRODUCTS

493 State Route 28
Richfield Springs, NY 13439

Phone: (315) 858-0055

www.andelaproducts.com
info@andelaproducts.com



- The Andela Metering Surge Hopper is designed to accept bulk loading of glass or other materials
- Holds 4 cubic yards, or up to 6 cubic yards with optional flared extensions (shown in picture)
- Reciprocating plate feeder meters the flow rate of material into the system
- Adjustable slide gate regulates whole, or mixed broken glass to desired throughput

- Simple to Operate & Maintain
- Easy Installation
- Reasonably Priced
- Heavy Duty Construction
- 18" or 24" wide Discharge
- Abrasion Resistant Materials on All Wear Surfaces



**ANDELA METERING SURGE HOPPER
MODEL AMSH86-18FS
with flared sides**

MACHINE SPECIFICATIONS

Dimensions

Capacity..... 6 to 7 cubic yds.
 Overall Length125”
 Overall Width101”
 Overall Height111”
 Discharge Opening18” wide x Adjustable Height
 Discharge Height40”

Drive Componentry

Motor Size(1) 3 hp
 Direct Drive System Totally Enclosed Gear Reducer
Reciprocating Plate with Eccentric Drive

Electrical

Motor Voltage..... 230/460 VAC, 60 HZ, 3 Phase
 (VAC and HZ provided to customer specifications)

Selected surfaces hardened for long wear and durability.

The manufacturer reserves the right to change designs
and specifications without notice.



Andela

Conveyors

Belt Width Options:
18", 24", 30" & 36"

Variable Lengths, Bed
Types, & Pans Available.

Stainless Steel Sections
for Crossbelt Magnets

Conveyor Types:
Slider Bed
Troughing Roll

Belt Tread Type:
Cleated belt
Smooth belt
Chevron belt



- Andela Conveyors are available in various sizes and configurations to fit any application
- Remote grease fittings and lines extend to base of conveyor for ease of maintenance

- **Increases Production**
- **Less Handling of Material**
- **Heavy Duty Construction**

ANDELA PRODUCTS

493 State Route 28
Richfield Springs, NY 13439

Phone: (315) 858-0055
Fax: (315) 858-2669

www.andelaproducts.com
info@andelaproducts.com

ANDELA SYSTEM CONVEYORS
MACHINE SPECIFICATIONS

Heavy Duty – Troughing

Overall Length/Width	According to Quotation
Drive System	3-phase motor and gear reducer, direct drive
Conveyor Body	10” x 3/16” formed steel channels
Carry Surface:	Troughing Roller
Belt	Smooth, chevron or cleared rubber belt
Head Pulley	10” head pulley
Tail Pulley	10” self cleaning tail pulley
Take Up	Adjustable Side Mounted bearings with 1 15/16” bore.
Returns	Return rolls with smooth and chevron belts Belly pans with wear resistant glides for cleared belt
Hopper/Sides/	Formed 10 gauge painted steel

The manufacturer reserves the right to change designs
and specifications without notice.