



# Andela

## GPT-1HD

### Glass Pulverizer/Screenener

**3-5 TPH  
Capacity**

**Accepts Bulk Quantities  
of Waste Glass Material**

**Generates Glass Sand  
and Gravel with Non-  
Glass Removed**

**Large Scale Features on a  
Small Scale Footprint**

*Environmentally friendly*

*Reduces waste*

*Provides cost effective remedy  
for environmentally conscious  
communities*

**ANDELA PRODUCTS**

493 State Route 28  
Richfield Springs, NY 13439

Phone: (315) 858-0055

[www.andelaproducts.com](http://www.andelaproducts.com)  
[info@andelaproducts.com](mailto:info@andelaproducts.com)

*GPT-1HD System*



- Pulverizer/trommel combination unit provides a condensed layout ideal for mounting on bunkers or legs.
  - Machine design features access doors with bolt in replacement liners and hammers for hassle free maintenance and service
  - Dual screening trommel size separates glass sand and gravel products for sale and use in the community.
  - Material uses include: backfill, drainage, filtration media, glass-phalt, decorative landscape mulch and so much more!
- **Simple Operation & Maintenance**
  - **Easy Installation**
  - **Reasonably Priced**
  - **Lined Wear Surfaces for Added Durability**
  - **Single Frame Construction**
  - **Generates Glass Product with No Sharp Edges**

**ANDELA GLASS PULVERIZER**  
**MODEL GPT-1HD**  
**(3-5 tons/hr. capacity)**  
**MACHINE SPECIFICATIONS**

**Dimensions**

Overall Length ..... Approx. 14 ft.  
Overall Width ..... Approx. 5 ft. 4 in.  
Overall Height ..... Approx. 9 ft.

**Pulverizer**

Machine Input Opening..... 14” x 14”  
Input Chamber Diameter and Length ..... 20” x 44”  
Chamber Type ..... Steel Frame & Heavy Duty Support Stand  
Liners ..... Bolt-in Heavy Duty Abrasion Resistant Steel  
Motor Size ..... One (1) 10 hp TEFC  
Solid Steel Shaft Diameter ..... 2.5” Dia.  
Number of Hammers ..... 24  
Hammer Type..... Flexible Impactor/Hardened Steel  
Bearing Size ..... 2.5” Dia. Heavy Duty  
Seal Protection..... Two (2) Seals at Shaft Bearing

**Trommel**

Screen #1 ..... 30” OD x 3’ long, 3/16” or to specification  
Screen #2 ..... 30” OD x 3’ long, 7/16” or to specification  
Screen Type ..... Stainless Steel Woven Wire  
Rotating Brushes ..... (2) - 7” diameter  
Motor Size ..... (1) 1 1/2 hp  
Direct Drive System ..... Totally Enclosed Gear Reducer, Flexible Mount

**Safety & Maintenance Features**

Protective Guards ..... Cover Input Hopper, Drive Unit and Bearings  
Maintenance Features..... Central lubrication Block, External Mount  
Enclosure ..... Complete Sheet Metal Enclosure  
..... Hinged Service Door for Inspection, Screen & Brushes Dust Control  
Misting System ..... Submersible Pump with Adjustable Spray Nozzle

**Electrical**

Motor Voltage ..... 230/460 VAC, 60 HZ, 3 Phase  
(Motor VAC and HZ provided to customer specifications)

The manufacturer reserves the right to change designs and specifications without notice.

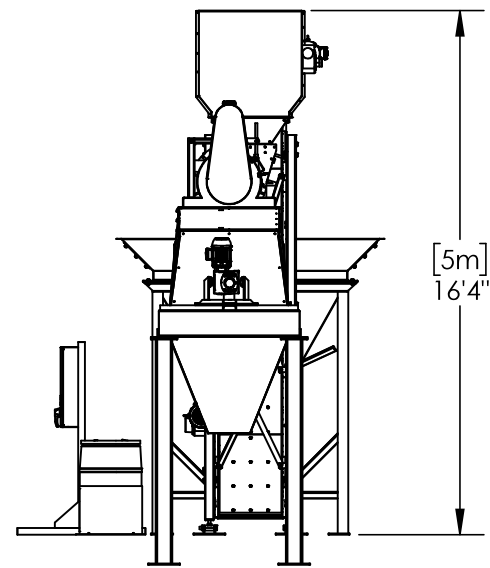
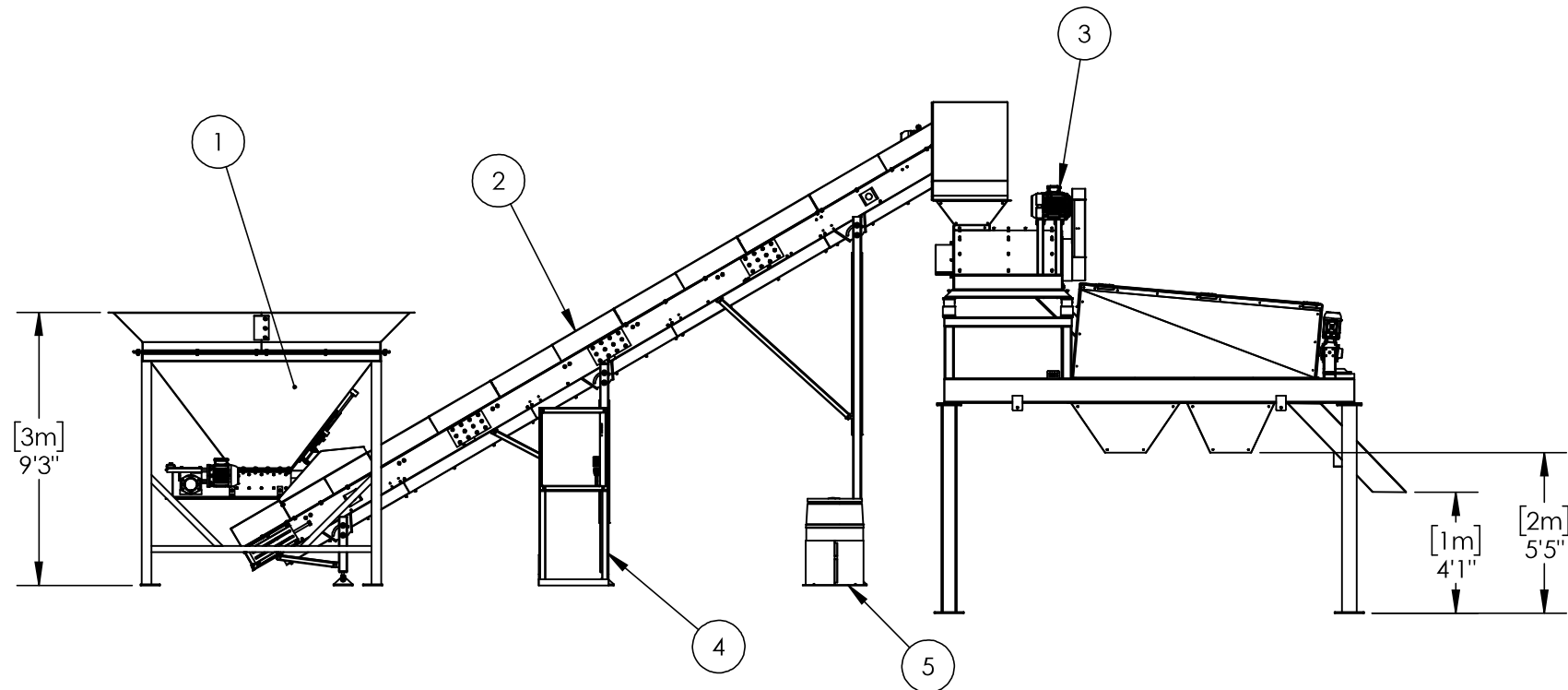
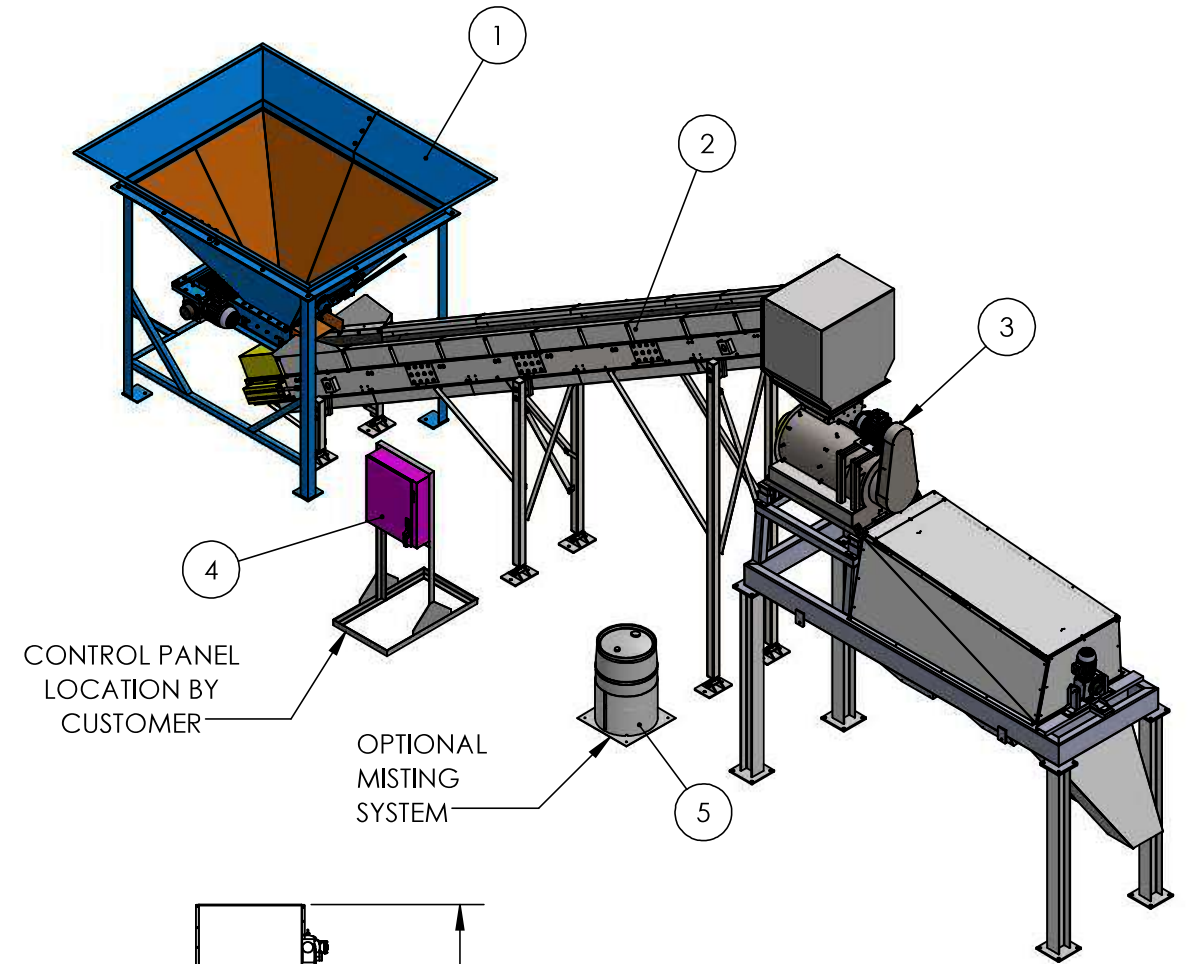
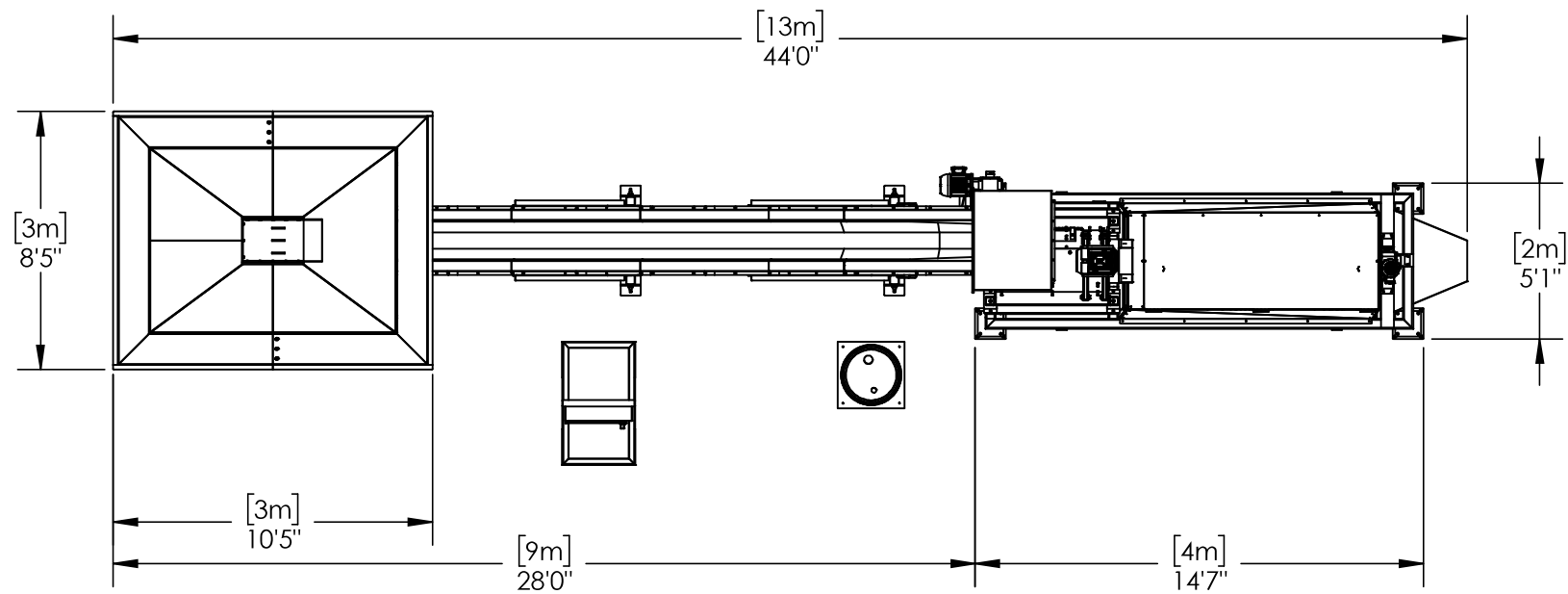

ITEM	DESCRIPTION	HP	QTY
1	AMSH86 SURGE HOPPER	3 HP	1
2	18" X 28' CONVEYOR	3 HP	1
3	GPT1-1HD GLASS PULVERIZER	10 HP / 1.5 HP	1
4	CONTROL PANEL	N/A	1
5	OPTIONAL MISTING SYSTEM	1/12 HP	1



493 State Route 28  
Richfield Springs, NY 13439

Tel: 315-858-0055  
andelaproducts.com

DRAWN JEA
DATE 1/30/2024
CHECKED
DATE
SCALE 1:72

GPT1-1HD SYSTEM  
GPT1-1HD SYSTEM LAYOUT

ANDELA PRODUCTS

GPT1-1HD

SHEET 1 OF 1

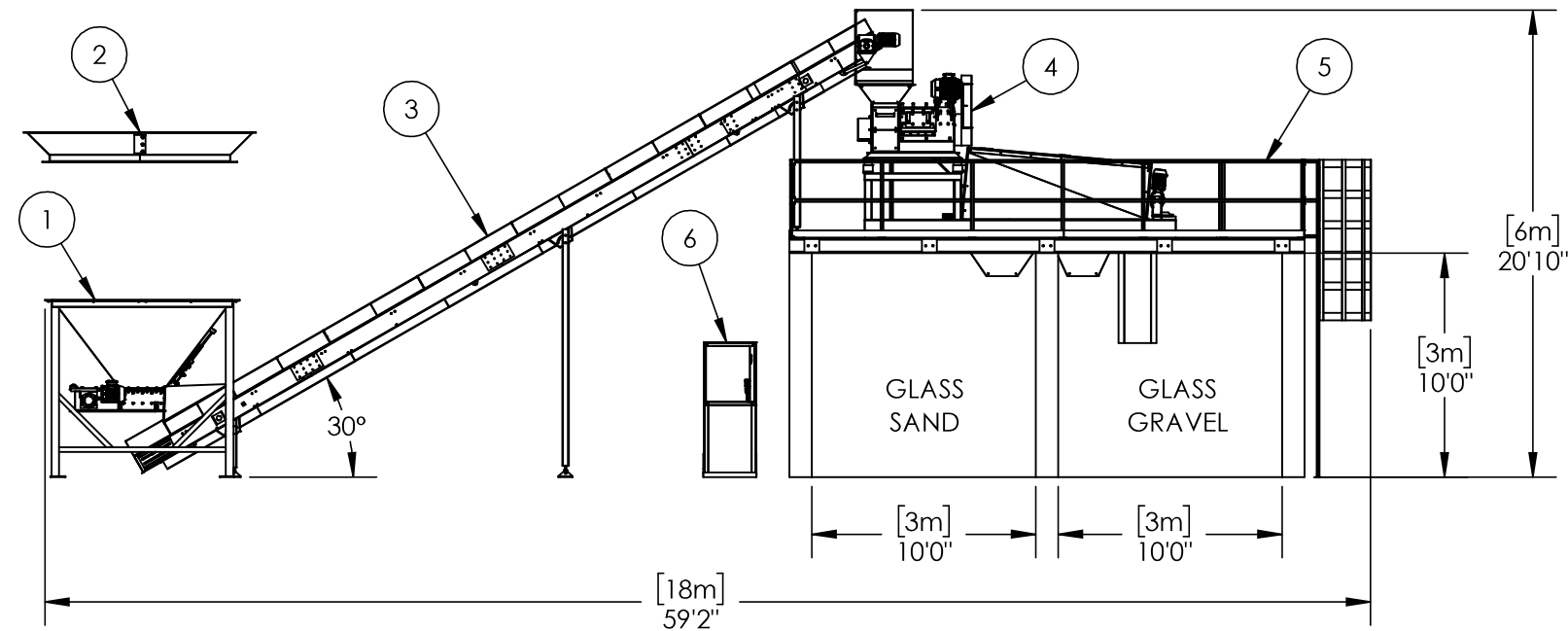
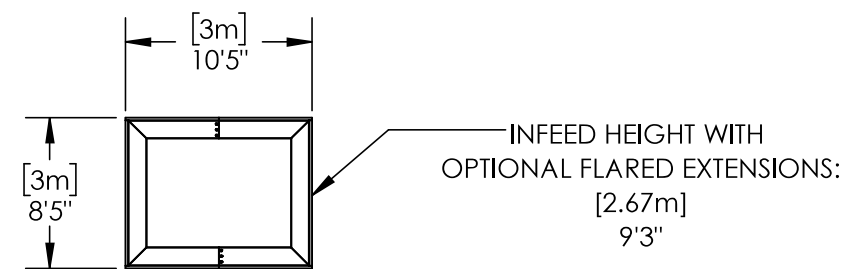
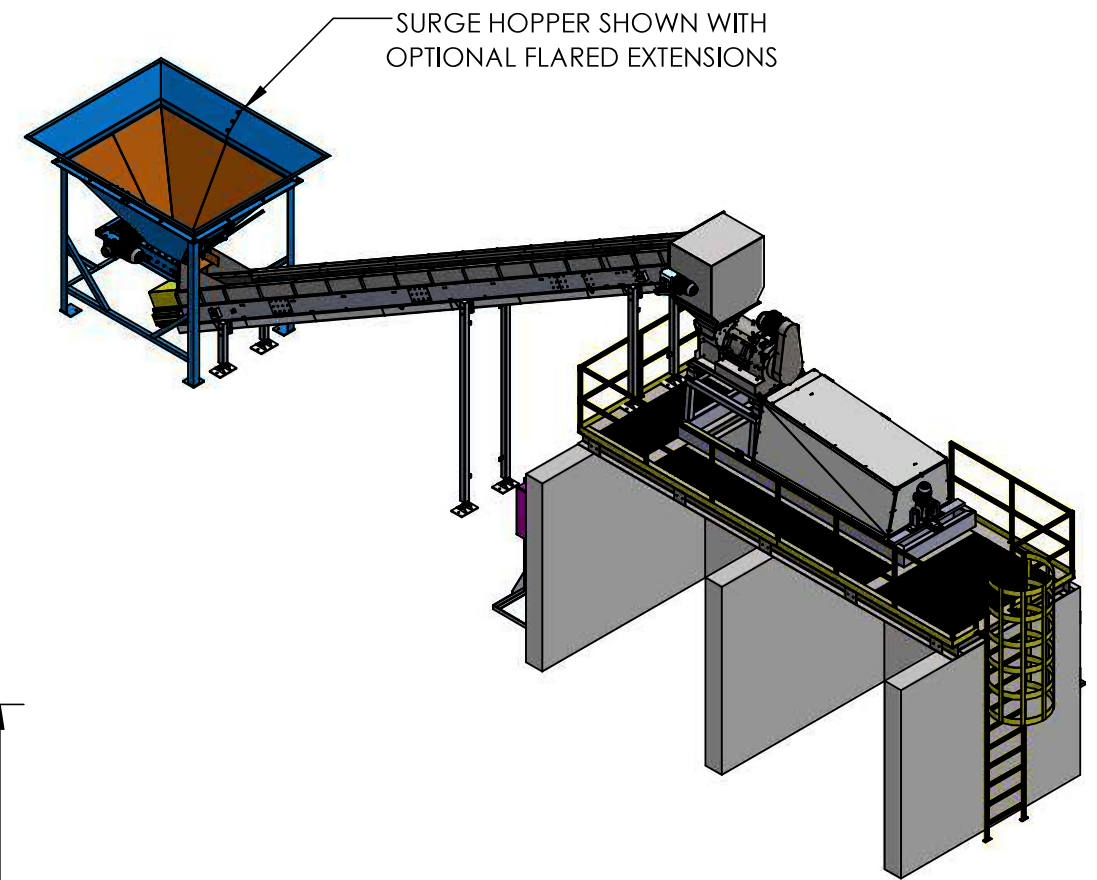
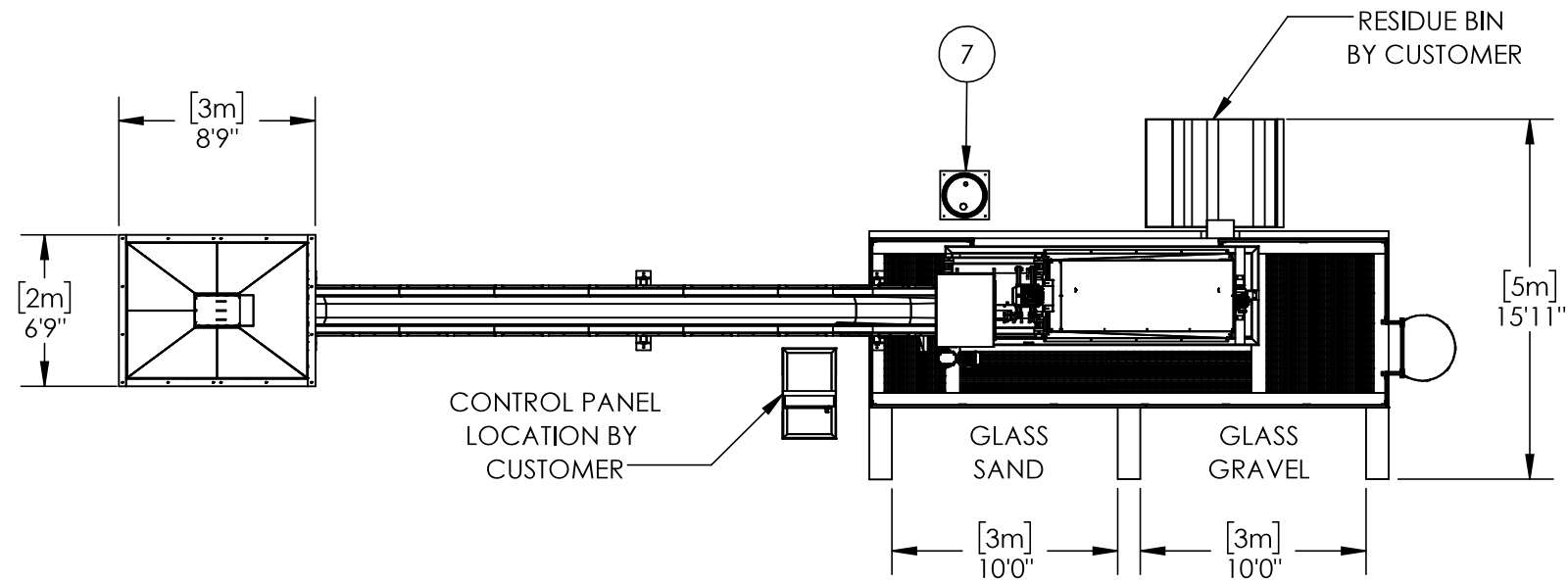

ITEM NO.	DESCRIPTION	HP
1	AMSH86 SURGE HOPPER	3 HP
2	OPTIONAL FLARED EXTENSIONS	N/A
3	18" x 38' TR CONVEYOR	5 HP
4	GPT-1HD PULVERIZER	10 HP/1.5 HP
5	SERVICE PLATFORM	N/A
6	CONTROL PANEL	N/A
7	OPTIONAL MISTING SYSTEM	1/12 HP



493 State Route 28  
Richfield Springs, NY 13439  
Tel: 315-858-0055  
andelaproducts.com

DRAWN BY:  
MB  
MODELED BY:  
BMT  
DATE  
1/30/2024  
CHECKED BY:  
SCALE  
1:128

GPT-1HD SYSTEM ON BUNKER

ANDELA PRODUCTS

REVISION	DATE	FILE NO.

ALL EQUIPMENT PAINTED RAL-5015 SKY BLUE, ALL GUARDS AND RAILINGS PAINTED RAL-1023 TRAFFIC YELLOW, AND ALL PLATFORMS PAINTED RAL-9017 TRAFFIC BLACK, UNLESS OTHERWISE NOTED.

GPT-1HD

SHEET 1 OF 1



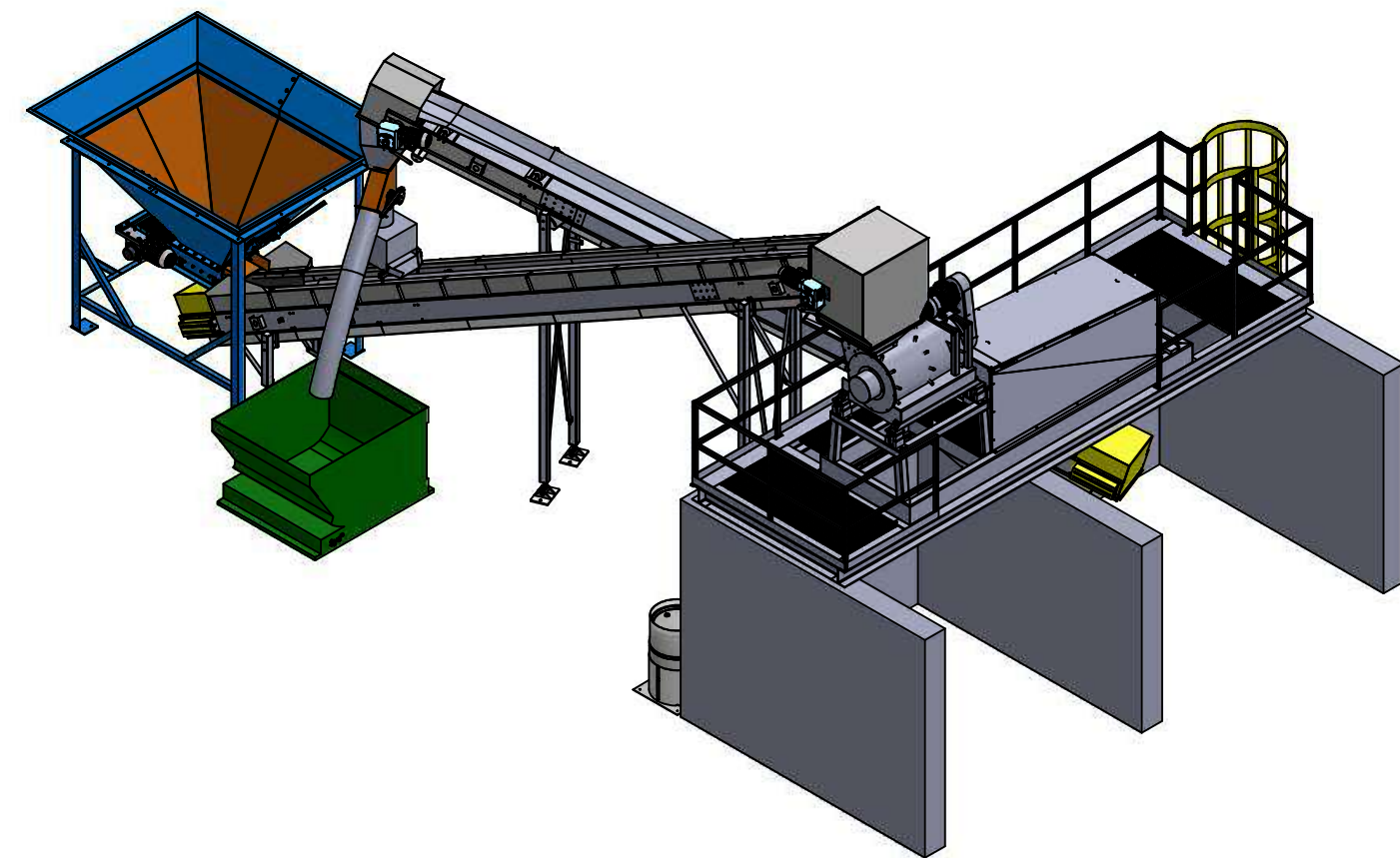
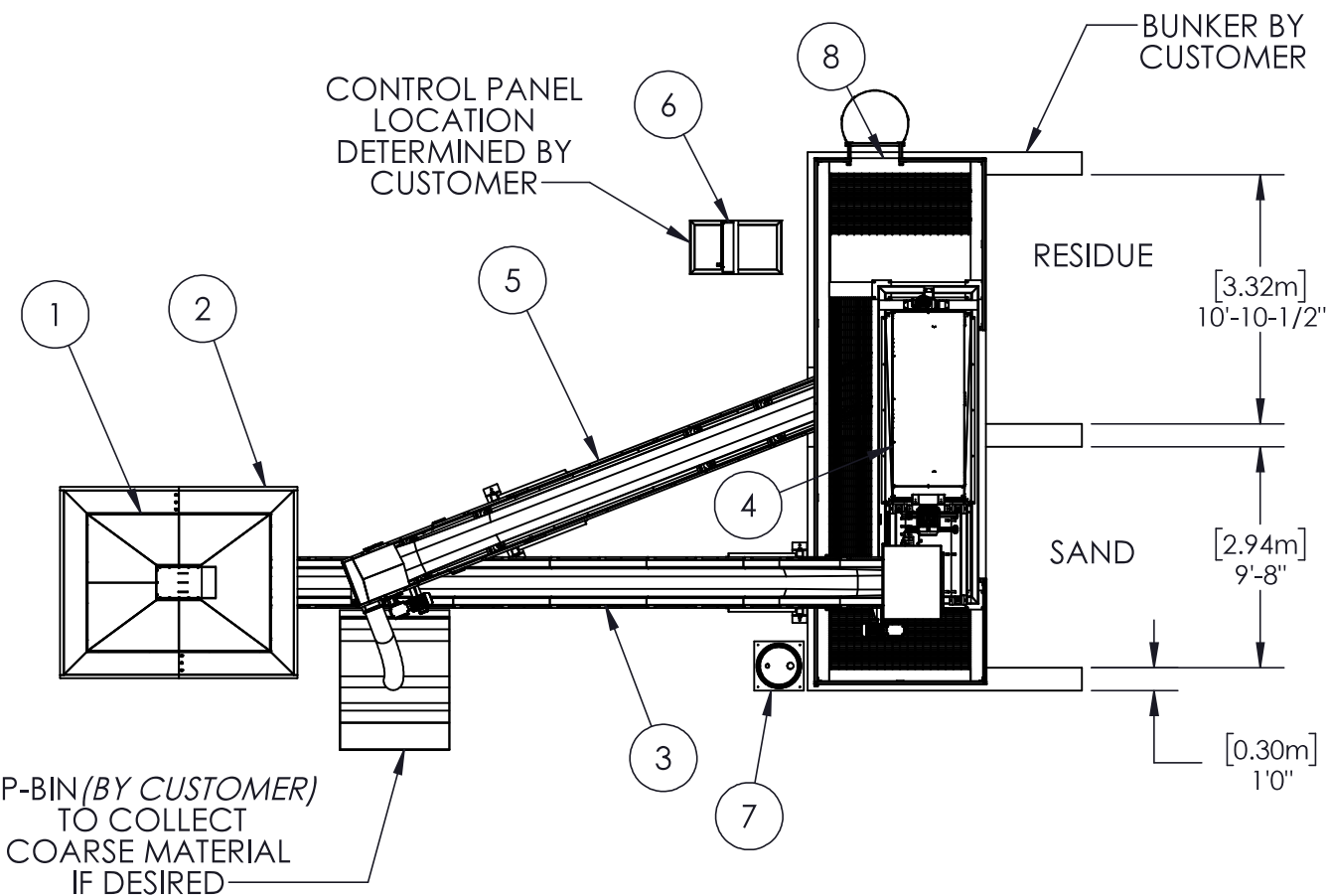

NOTE: OPTIONAL FLARED EXTENSIONS INCREASES INFEED HEIGHT TO 9'3" [2.82m]

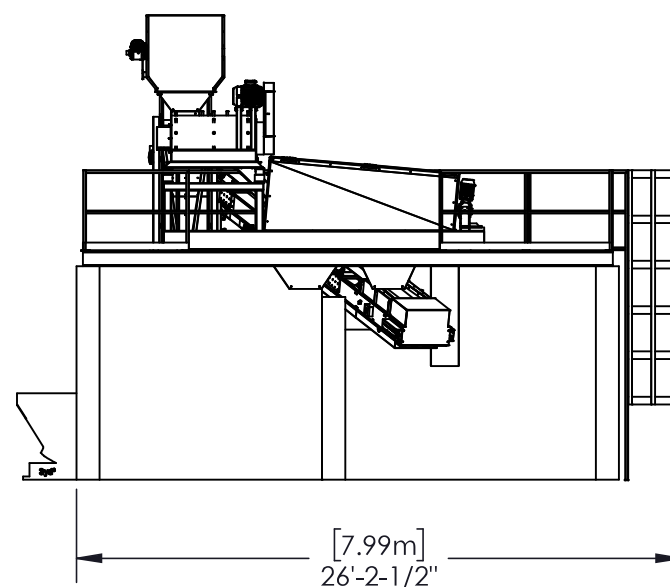
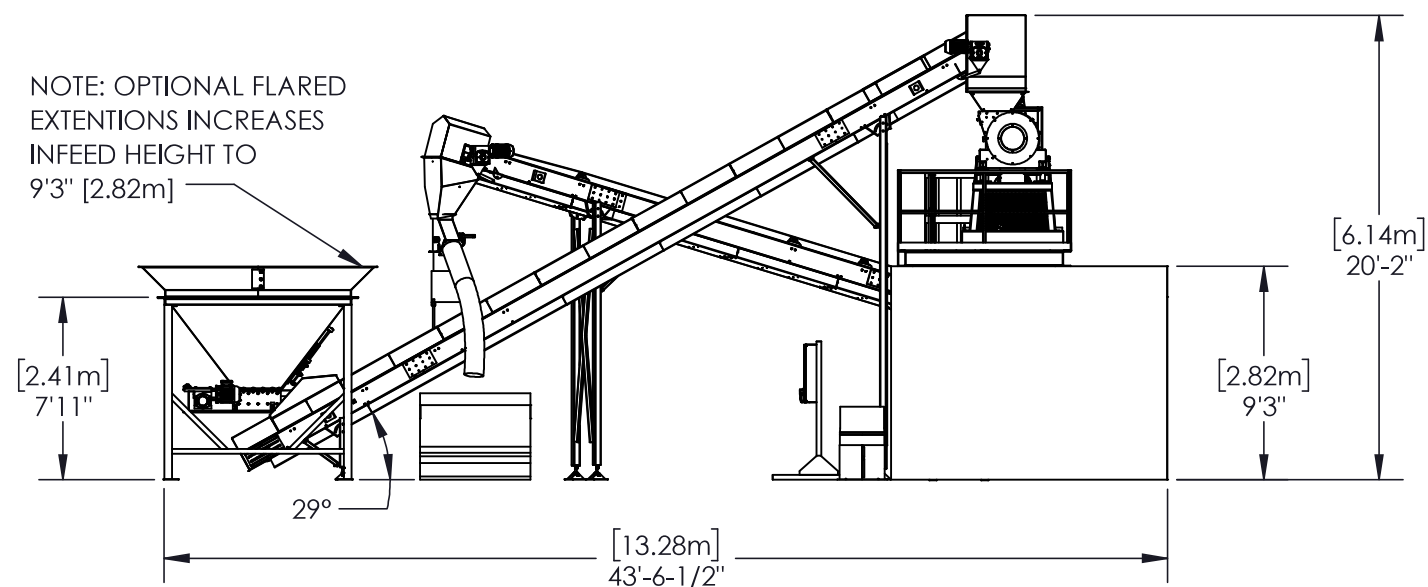

ITEM NO.	DESCRIPTION	HP
1	AMSH-86-18	3 HP
2	OPTIONAL FLARED EXTENSIONS	N/A
3	18"x36' GPT-1HD INFEED CONVEYOR	5 HP
4	GPT-1HD PULVERIZER	10 H.P. / 11.5 H.P.
5	18"x28' RECIRC CONVEYOR	3 HP
6	Control Panel	N/A
7	OPTIONAL MISTING SYSTEM	1/12 HP
8	SERVICE PLATFORM	N/A



493 State Route 28  
Richfield Springs, NY 13439  
Tel: 315-858-0055  
andelaproducts.com

DRAWN JEA
DATE 1/30/2024
CHECKED
DATE
SCALE 1:100

GPT-1HD  
GPT1-HD SYSTEM ON BUNKERS W/  
RECIRC

ANDELA PRODUCTS

REVISION	DATE	FILE NO.

GPT-1HD

SHEET 1 OF 1



# Andela

## Hoppers

### Surge Hopper

**Evenly Distributes  
Material**

**Essential for Bulk  
Loading**

**Models:**

AMSH86-18

AMSH86-24

*Environmentally friendly*

*Reduces waste*

*Provides cost effective remedy  
for environmentally conscious  
communities*

**ANDELA PRODUCTS**

493 State Route 28  
Richfield Springs, NY 13439

Phone: (315) 858-0055

[www.andelaproducts.com](http://www.andelaproducts.com)  
[info@andelaproducts.com](mailto:info@andelaproducts.com)



- The Andela Metering Surge Hopper is designed to accept bulk loading of glass or other materials
- Holds 4 cubic yards, or up to 6 cubic yards with optional flared extensions (shown in picture)
- Reciprocating plate feeder meters the flow rate of material into the system
- Adjustable slide gate regulates whole, or mixed broken glass to desired throughput

- **Simple to Operate & Maintain**
- **Easy Installation**
- **Reasonably Priced**
- **Heavy Duty Construction**
- **18" or 24" wide Discharge**
- **Abrasion Resistant Materials on All Wear Surfaces**

**ANDELA METERING SURGE HOPPER  
MODEL AMSH86F-18  
with flared sides**

**MACHINE SPECIFICATIONS**

Dimensions

Capacity..... 6 to 7 cubic yds.  
Overall Length .....125”  
Overall Width .....101”  
Overall Height .....111”  
Discharge Opening .....18” wide x Adjustable Height  
Discharge Height .....40”

Drive Componentry

Motor Size .....(1) 3 hp  
Direct Drive System ..... Totally Enclosed Gear Reducer  
.....Reciprocating Plate with Eccentric Drive

Electrical

Motor Voltage..... 230/460 VAC, 60 HZ, 3 Phase  
(VAC and HZ provided to customer specifications)

Selected surfaces hardened for long wear and durability.

The manufacturer reserves the right to change designs  
and specifications without notice.



# Andela

## Conveyors

Belt Width Options:  
18", 24", 30" & 36"

Variable Lengths, Bed  
Types, & Pans Available.

Stainless Steel Sections  
for Crossbelt Magnets

**Conveyor Types:**  
Slider Bed  
Troughing Roll

**Belt Tread Type:**  
Cleated belt  
Smooth belt  
Chevron belt



### ANDELA PRODUCTS

493 State Route 28  
Richfield Springs, NY 13439

Phone: (315) 858-0055

[www.andelaproducts.com](http://www.andelaproducts.com)  
[info@andelaproducts.com](mailto:info@andelaproducts.com)

- Andela Conveyors are available in various sizes and configurations to fit any application
- Remote grease fittings and lines extend to base of conveyor for ease of maintenance

- **Increases Production**
- **Less Handling of Material**
- **Heavy Duty Construction**



**ANDELA SYSTEM CONVEYORS**  
**MACHINE SPECIFICATIONS**

**Heavy Duty – Troughing**

<b>Overall Length/Width</b>	According to Quotation
<b>Drive System</b>	3-phase motor and gear reducer, direct drive
<b>Conveyor Body</b>	10” x 3/16” formed steel channels
<b>Carry Surface:</b>	Troughing Roller
<b>Belt</b>	Smooth, chevron or cleared rubber belt
<b>Head Pulley</b>	10” head pulley
<b>Tail Pulley</b>	10” self cleaning tail pulley
<b>Take Up</b>	Adjustable Side Mounted bearings with 1 15/16” bore.
<b>Returns</b>	Return rolls with smooth and chevron belts Belly pans with wear resistant glides for cleated belt
<b>Hopper/Sides/</b>	Formed 10 gauge painted steel

The manufacturer reserves the right to change designs  
and specifications without notice.